

## KaDEr Gelderland Project Expositie Ontwerpprojecten MSc 2, 3/4 studenten TU Delft







# KaDEr Gelderland

## Karakteristiek Duurzaam Erfgoed

Hielkje Zijlstra & Paul Thissen, Tom Pegels  
Steffen Nijhuis, Gerdy Verschuuren, Hilde Remøy & Monique de Rooij  
Wido Quist, Eric van den Ham & Joop Heijdra, Leo Lussenburg  
Lidwine Spoomans, Sara Stroux & Vincent Vleeshouwers, Sandra ten Wolde  
Alexander de Ridder, Job Roos, Lidy Meijers, Bas Gremmen, Nicholas Clarke

**Het KaDEr Gelderland project staat voor Karakteristiek Duurzaam Erfgoed in Gelderland.** De Technische Universiteit Delft en de Provincie Gelderland werken samen om een impuls te geven aan de inbedding van duurzaamheid bij het in standhouden van gebouwd erfgoed, met respect voor de monumentale waarden, in beleid en praktijk met kennis en kunde.

We doen dit middels analyses van het verleden en monitoren van het heden om richting te geven aan de toekomst via vier Living Lab's op vier schaalniveaus: XL / L / M / S, waarin we projecten volgen in de praktijk, studenten inzetten op ontwerpvragestukken en acht specifieke deelprojecten uitvoeren.

Van 2017 tot 2021 werken we aan diverse projecten. Alleen door verandering kan een duurzame bestemming van erfgoed plaatsvinden. Samen onderzoeken we welke veranderingen dit beleidsmatig kunnen zijn.

Hierbij zal de klassieke, object gerichte, restauratie-opdracht plaats moeten gaan maken voor DUURZAAM en dus toekomstbestendig beheer, waarbij de volgende DUURZAAMHEIDS thema's zijn leidend:

- 1. Energetische duurzaamheid**
- 2. Financieel gezond perspectief**
- 3. Functioneel gebruik**
- 4. Het borgen van kennis op lange termijn**

Hierbij wordt alles in balans gebracht met de monumentale waarden en wordt DUURZAAMHEID in een zo breed mogelijk denkraam geplaatst. Het borgen van vakmanschap en de kennisoverdracht middels educatieve momenten onder direct betrokkenen wordt gestimuleerd. Daarbij betrekken we studenten van de TU Delft en leerlingen vanuit de vakopleidingen bij de projecten zelf.



Living Lab **XL** - Stad



Living Lab **L** - Landgoed



Living Lab **M** - Kerken



Living Lab **S** - Gebouw



Mini symposium Klein Vaticaan in Zutphen op 11 juni 2018





# KaDEr Gelderland & TU Delft Onderwijs-ontwerpprojecten

MSc3/4 Klein Vaticaans Zutphen  
MSc3/4 Landgoed Reuversweerd  
MSc2 Presikhaaf Arnhem  
MSc2 Drie Kerken in Gelderland

## Heritage & Architecture & KaDEr Gelderland MSc studio's TU Delft

Aan de Living Lab's van het KaDEr project worden ieder half jaar onderwijs-ontwerpprojecten gekoppeld in het Master of Science programma van de TU Delft faculteit Bouwkunde - sectie Heritage & Architecture.

### 2017-2018 LLAB-XL-Stad - Zutphen: Klein Vaticaans

Voor de locatie van de scholen, pastorie, Nieuwstadskerk en St. Elisabeth hebben twintig studenten plannen gemaakt voor het herontwerp van deze gebouwen in hun omgeving.

### 2018-2019 LLAB-S-Gebouw: Landgoed en landhuis Reuversweerd

Voor dit landhuis en bijgebouwen is door vijf studenten een plan gemaakt met uiteenlopende, inspirerende, programma's van hotel, trouwlocatie tot foodcourt.

### 2018-2019 LLAB-XL-Stad: Arnhem Presikhaaf

Voor de locaties om en nabij het winkelcentrum zijn ontwerpen gemaakt door achttien studenten om de woningbouwblokken en de voorzieningen op buurtniveau te revitaliseren.

### 2018-2019 LLAB-M- Kerken: drie kerken in Gelderland

Er zijn door 28 studenten ideeën ontwikkeld voor het herbestemmen van drie kerken in Gelderland: de St. Maartenskerk in Tiel, de Nieuwstadskerk in Zutphen en de Walburgiskerk in Arnhem.

Tijdens de onderwijsprojecten wordt eerst is een analyse gemaakt vanuit architectonisch, technisch en cultuur historisch perspectief. Vervolgens wordt een programma van eisen ontwikkeld en daarna wordt een ontwerp gemaakt. Daarbij staan met name twee thema's vanuit het KaDEr project centraal: **energetische duurzaamheid en functionele bruikbaarheid.**



Klein Vaticaans Zutphen



Landgoed Reuversweerd



Arnhem Presikhaaf

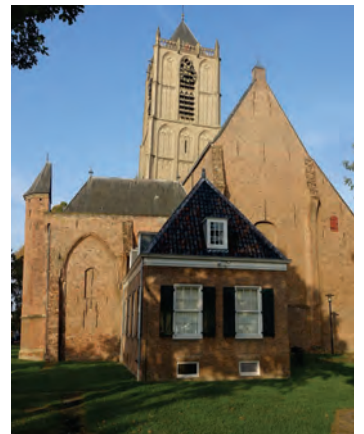

Drie Kerken in Gelderland: Arnhem, Tiel en Zutphen



Leren van de praktijk op de steigers van Reuversweerd



# IN-BETWEEN CITY & PARK

Malon Houben  
The Netherlands

## transforming Baudartius College

Baudartius College is a high school designed by **Jan Rotshuizen** in the 1950s. A building with many different architectural languages. This due to the fact that it is not built in once, first a L-shape floor plan in 1950, and in 1955 a floor plan with a courtyard in the middle. A communal place, with its own **atmosphere** and **characteristics**. In the sixties it was necessary to expand the school further. Step

by step the courtyard was completely filled in, the original atmosphere is lost and it is now an island in the city.

The new design is one **large complex** along the Isendoornstraat (inspired by the Isendoorn barracks from 1830 till 1944). The complex will include two wings: **work expo** and a **student hotel**. A complex that not only functions **between city and**

**park**, but also a complex that **connects** the area **Nieuwstad** again with the **old city center**. Different target groups will be attracted: creative students from Aventus, start-ups, local people and tourists. By mixing different target groups, the environment will become **lively** and young people become part of the city again.

The focus of this poster is the work expo in the current

Baudartius College. The first step is opening up the building to get back the atmosphere. Second, three new volumes will be added: **courtyard, expo hall and corridor**. This makes the building ready for the future generation.

- |                |                    |
|----------------|--------------------|
| 1. Entrance    | 5. Auditorium      |
| 2. Shops       | 6. Library         |
| 3. Offices     | 7. Coffee Bar      |
| 4. Work Spaces | 8. Exhibition Hall |



Masterplan

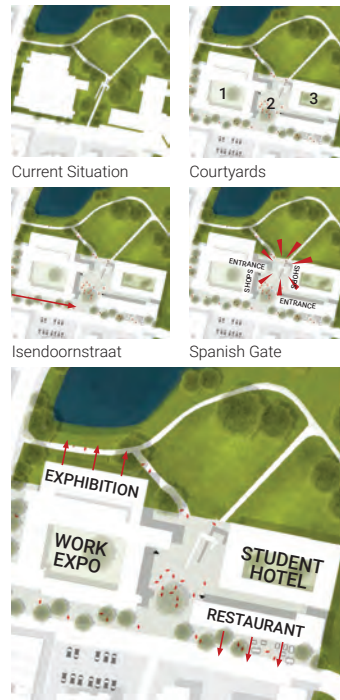

New intervention

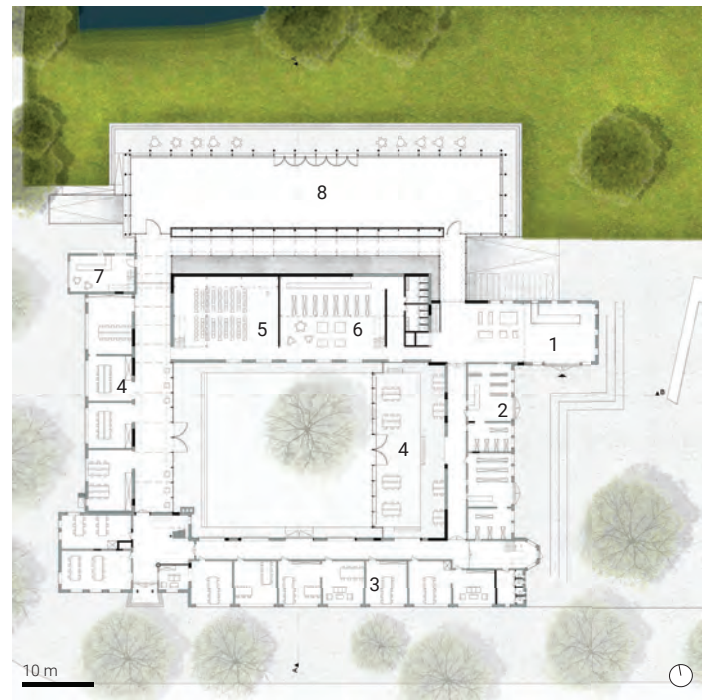

Ground Floor



Section

ISENDOORNSTRAAT ——— OFFICES ——— COURTYARD

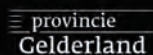

# IN-BETWEEN CITY & PARK

transforming Baudartius College

Malon Houben  
The Netherlands

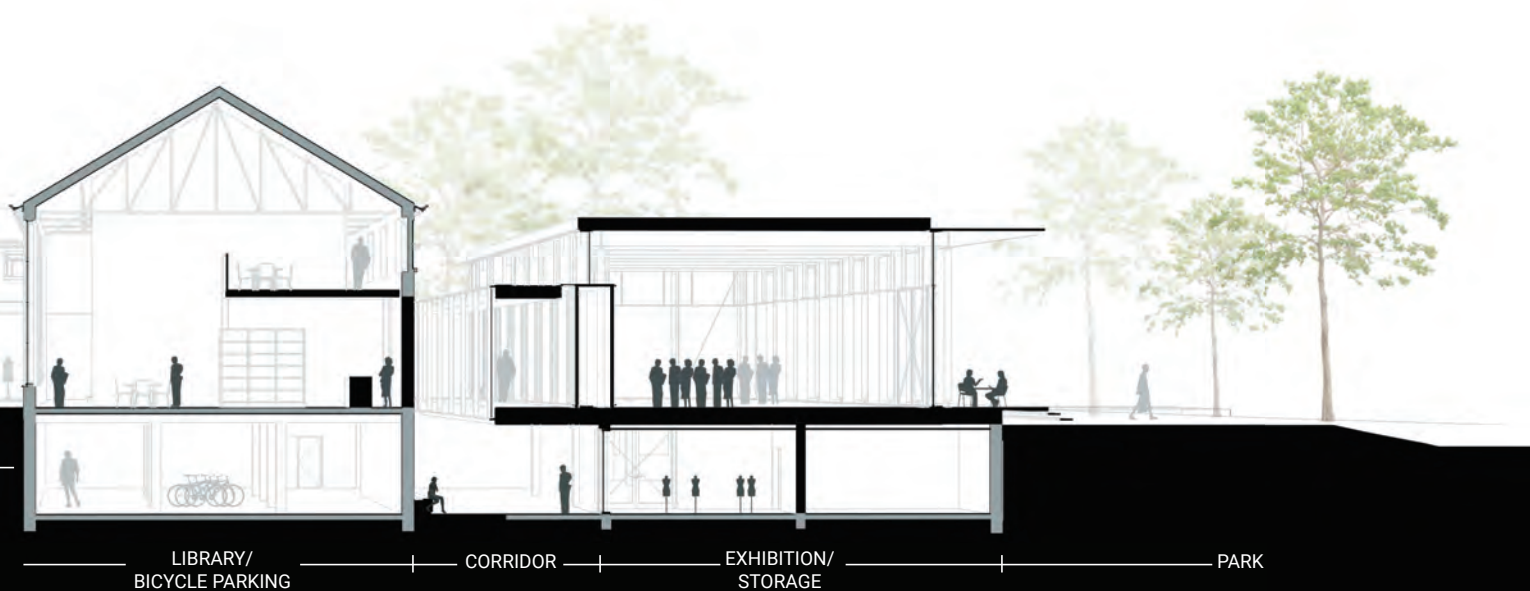
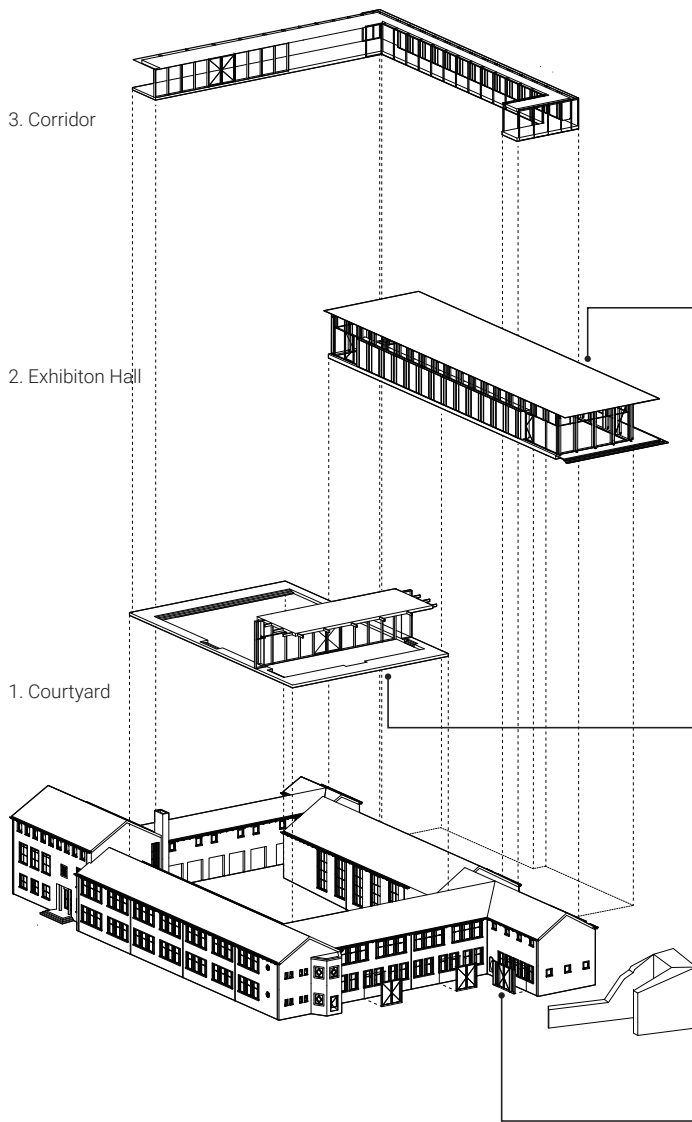



# IDENTITY & HERITAGE IN URBAN REGENERATION

## St. Elisabeth - an elder-centred community design

### Design essential: courtyards as identity carriers and spatial organizers in urban regeneration

Zutphen is one of the medieval cities in the Netherlands. During the historical development of the inner city, courtyard has always been an important identity of urban fabrics in this area. Especially, we can see that Luthersehofje is still functioning as a peaceful living space withdrawn from busy urban space. However, during the densification in the last decades, this identity is fading away.

Triggered by the aging issue in Zutphen, the vision for this area is to build an elder-centered community. In the intervention plan, this traditional dutch courtyard offers the most important inspiration for the design. In one word, this design could be

seen as an attempt of redensification of this urban area where several courtyards are embedded, making conversations with the heritages on site, serving as a transition space between the old and the new, and creating better urban living spaces.

In the focused design, there are (1) chapel courtyard and (2) city wall courtyards. The former is a new courtyard in between the renovated elderly home (north wing) and the new wellness center, which offers a public space for both the elderly and the visitors. The latter is enclosed by the city wall, the existing elderly home (south wing) and the new shared-housing volume. In addition, a new City Tower Square located in between these two groups of buildings is designed as a vibrant urban public space in the end of Geweldigershoeek. As a result, the historical tower will again be part of the urban life.

### Position in urban environment: a residential community located on the border of the inner city

Dating back to 1855, the first elderly home was built after the city wall was partly demolished. After times of transformation, the elderly home has been much expanded. In the current situation, the north wing is standing like a new city wall while the south wing sets back from the remained city wall. However, the volume of the building is growing out of control, threatening the intimate spaces and hiding the heritage behind.

In short, the location of the targeting buildings is important while the buildings should be contextualized to fit in the context of this historical area.

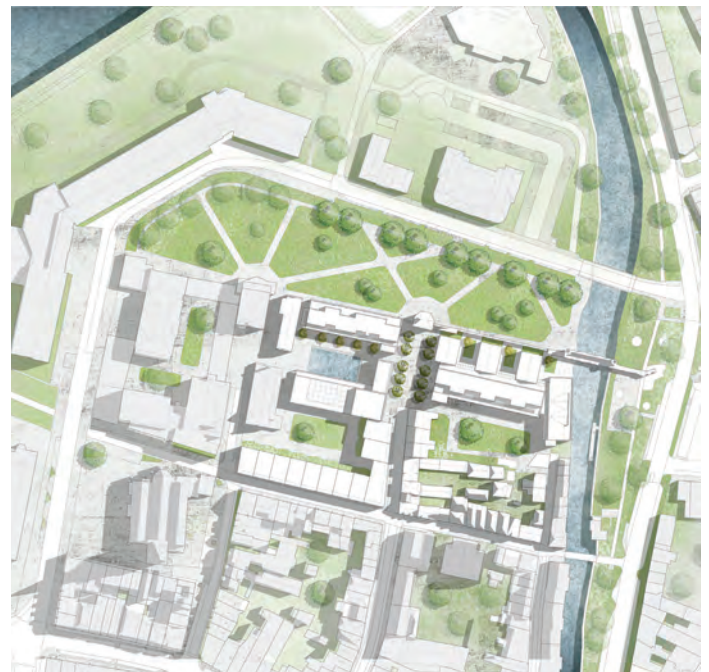

master plan - after intervention

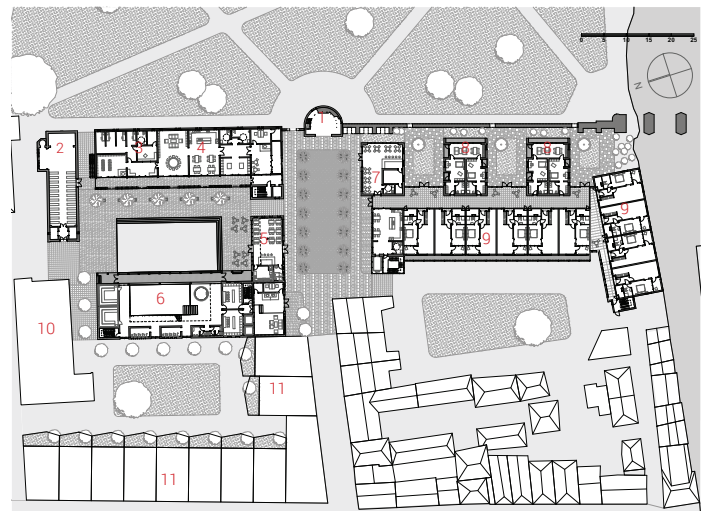
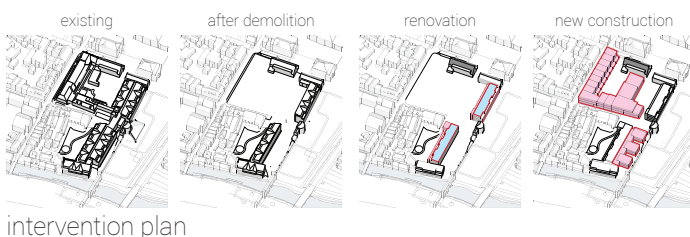

- 1 museum
- 2 library/theatre
- 3 clinic & pharmacy
- 4 elderly collective kit- chen and dining
- 5 restaurant
- 6 wellness center
- 7 cafe
- 8 new shared home
- 9 existing elderly home
- 10 elderly school
- 11 new family housing

# IDENTITY & HERITAGE IN URBAN REGENERATION

Chenbin Fu  
China

## St. Elisabeth - an elder-centred community design

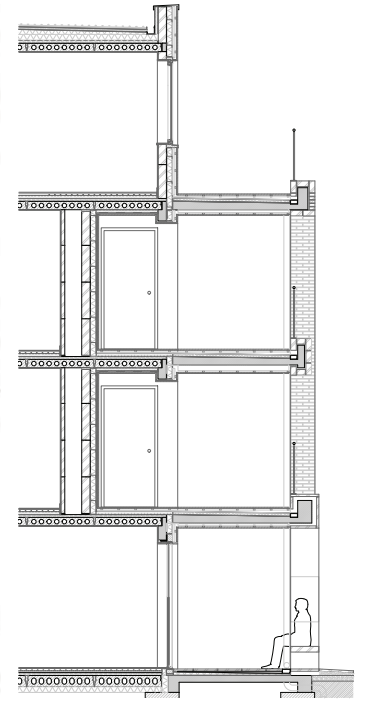
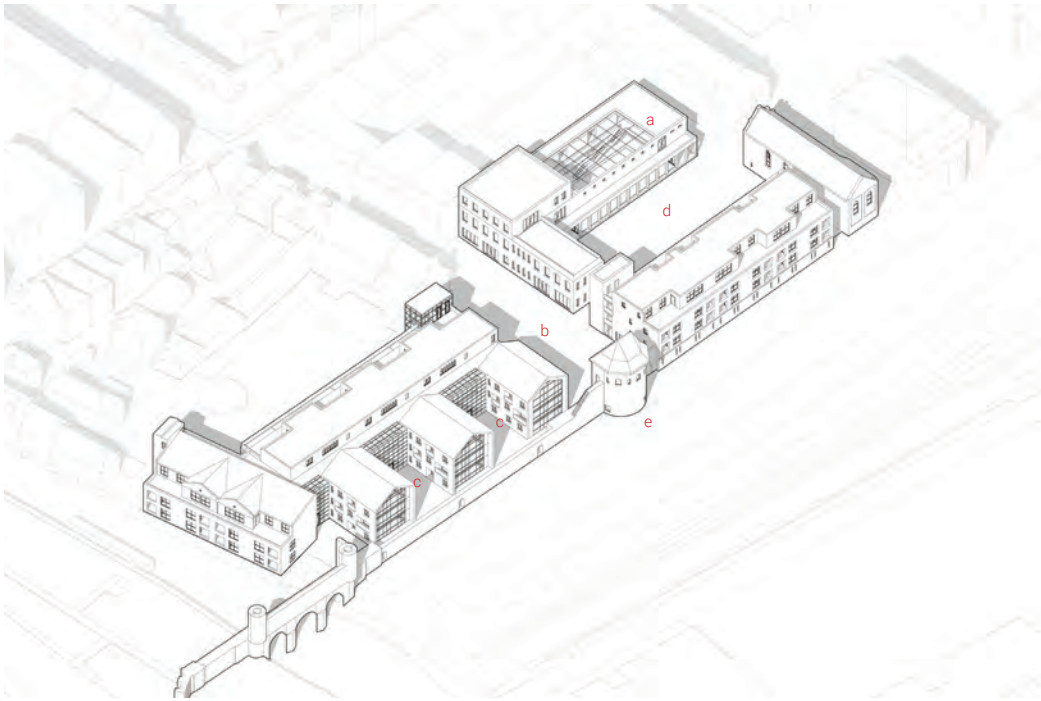

axonometric view

west facade renovation 1:20



a. spa area - interior courtyard



b. city tower square



c. city wall courtyard



d. chapel courtyard



e. garden facade (east)



# THE LEARNERS INSTITUTE

Sjoerd Marijnissen  
Netherlands

## a new educational typology

### The concept

Zutphen is known for its anthroposophic education and they claim it to be their speciality. But the educational system is outdated. K. Robinson, an educationalist, calls for schools to stimulate creativity. M. Csikszentmihalyi, also an educationalist defines creativity as something that happens in an existing cultural context. The term is related to community. Creativity consists of a talented individual, the domain (existing) and the field (an elite that controls the domain). This translates into the function, an institution with archives (domain) a school (talented individual) and a museum function (the field).

### The process

Design input is generated with (historical) analyses on urban, architectural, technical and cultural level. To gain input for the educational system a literature study has been done.

### The design

The design creates tension and intimacy well known to Zutphen. Porosity of the existing urban fabric inspires to let new courtyards emerge which create this intimacy. Borders are redefined and re-experienced on different levels. It elevates the current idea of a school and a museum.

The building has multiple entrances for different experiences, fragile children can use it on a small scale and others can experience the full capacity of the complex through space, light and scale. Although it seems radical it respects the values of the area and is derived from historical analysis. It tells multiple heritage stories and could make Zutphen truly a city well known for secondary education of the highest quality. Answering to the need of the current population and eventually attracting younger intellectual people.

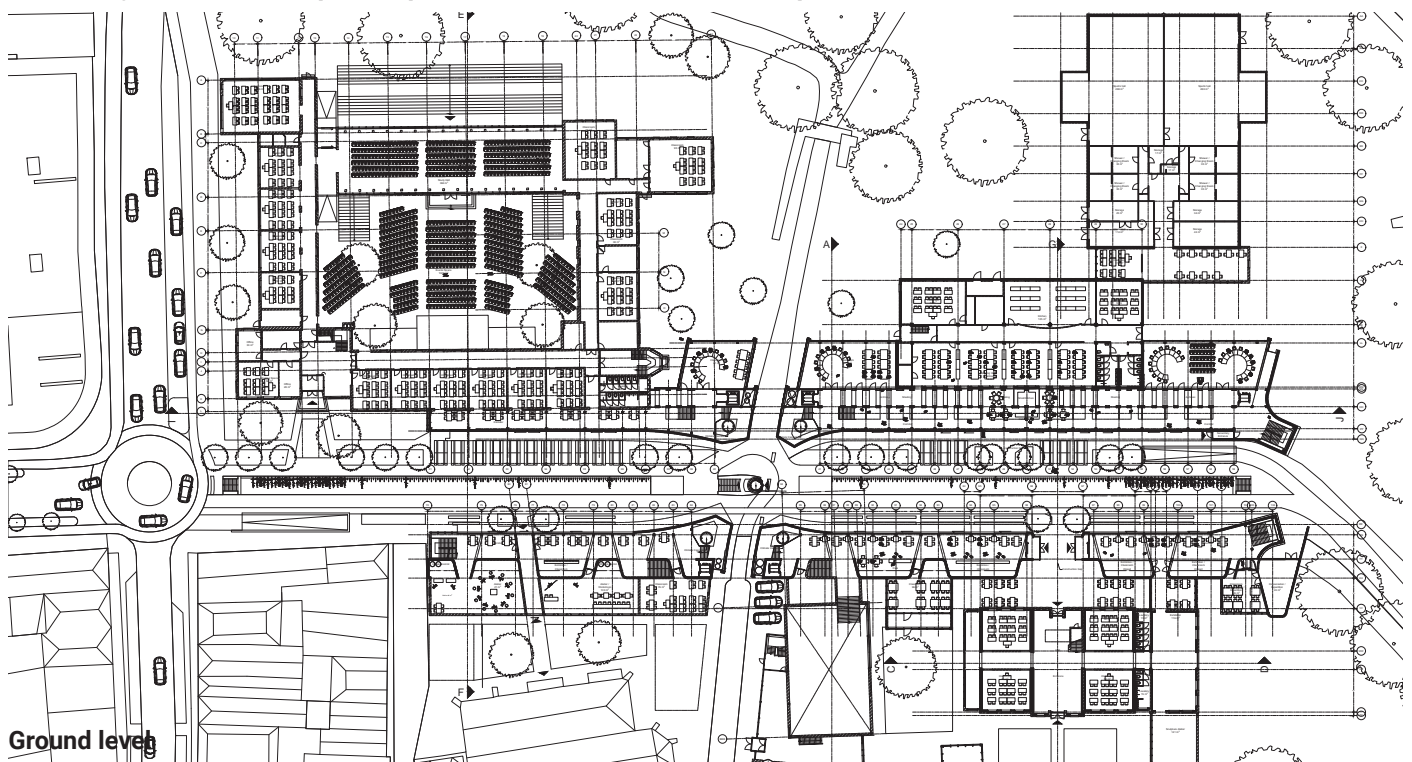
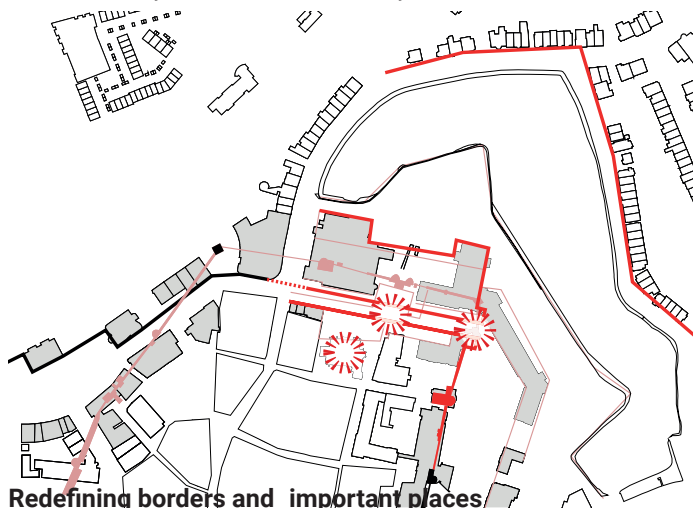



# THE LEARNERS INSTITUTE

a new educational typology

Sjoerd Marijnissen  
Netherlands

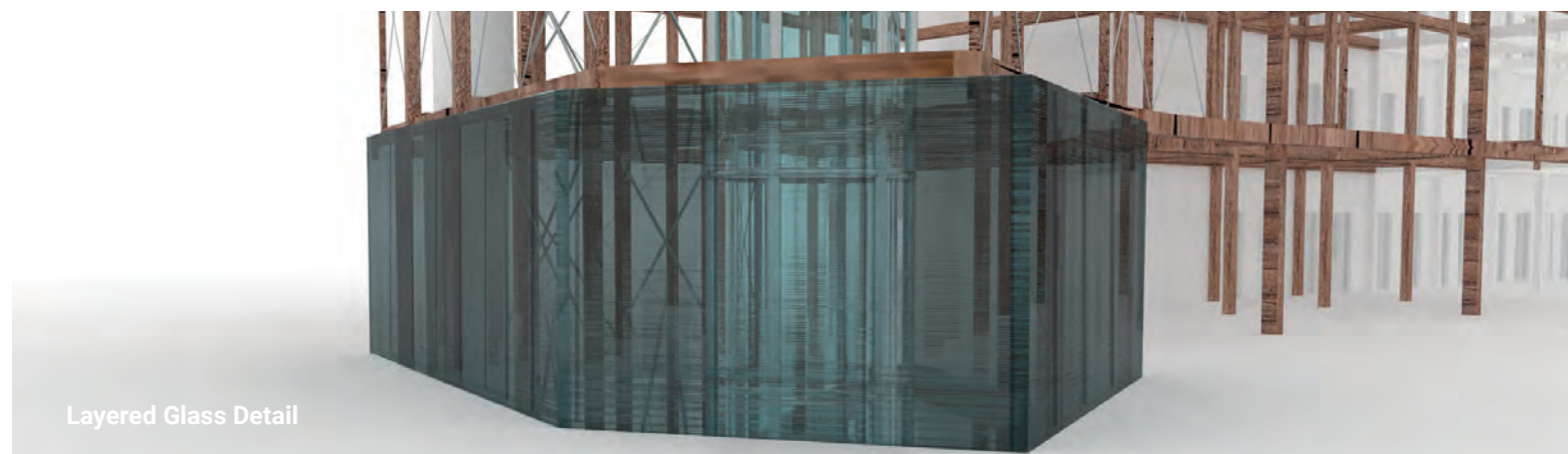
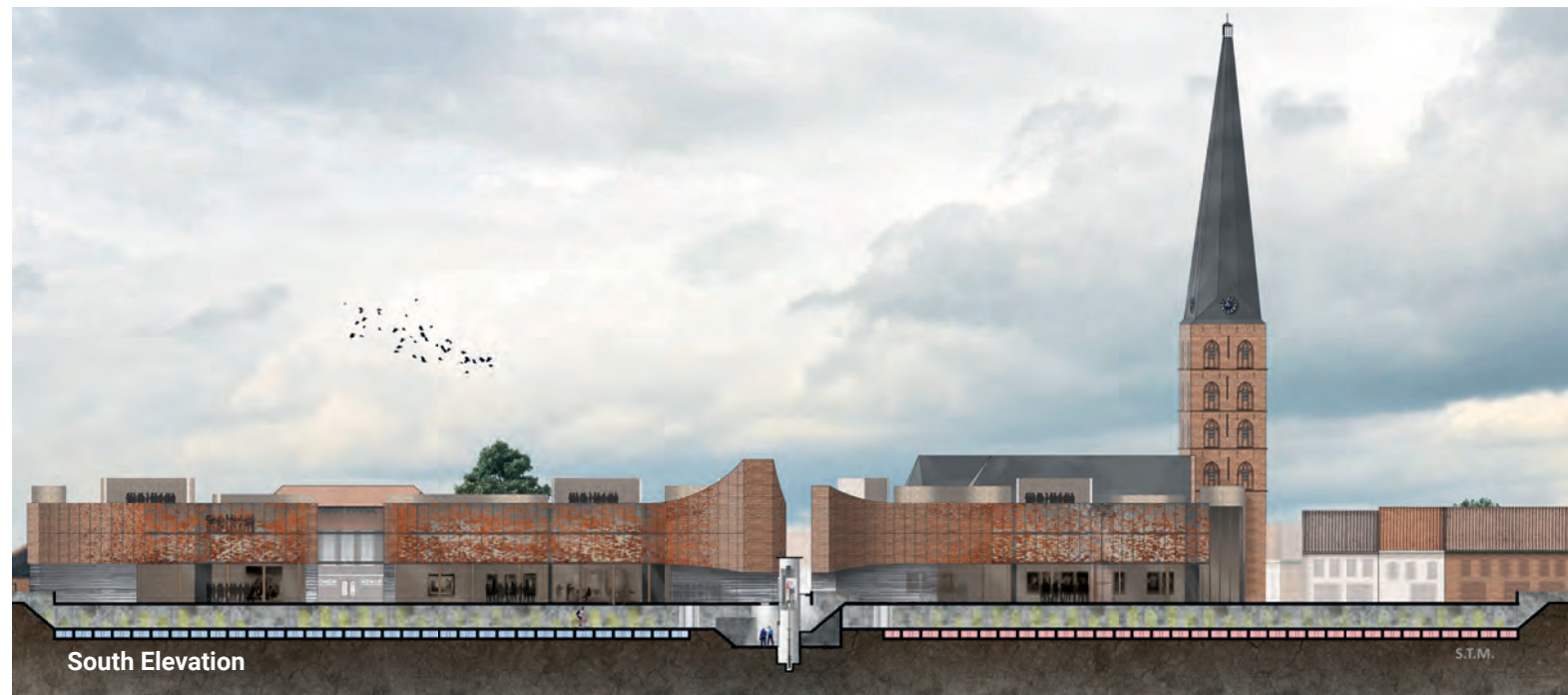



# Educational Agora of Klein Vaticaan.

new era for a school complex

George Sitarenios.  
Athens, GR.

Zutphen is arguably a city with glorious and rich past, fact reflected in its **rich architectural fabric**. Nowadays, especially in the area of **Nieuwstad**, it seems that it has to face several difficulties, primarily related with the constantly growing amount of youngsters choosing to study and work away from the area. This why my proposal aims in dealing with this issues and set a starting point for regeneration. My target is found in the field of **education** in a way that it will **attract youth** and new starters, simultaneously aiming to set an example for a broader **regenerator strategy** based on vocational education, along with the establishment of a reputation for Nieuwstad related with **students' training in the creative industry**.

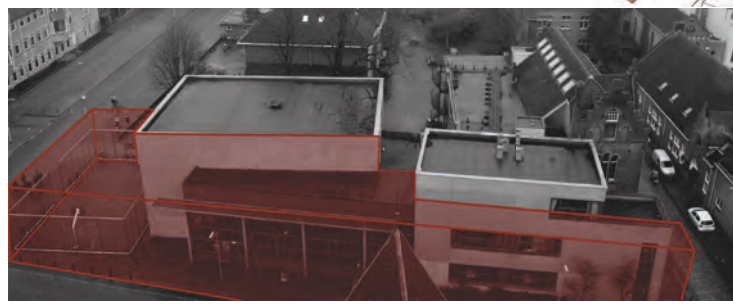
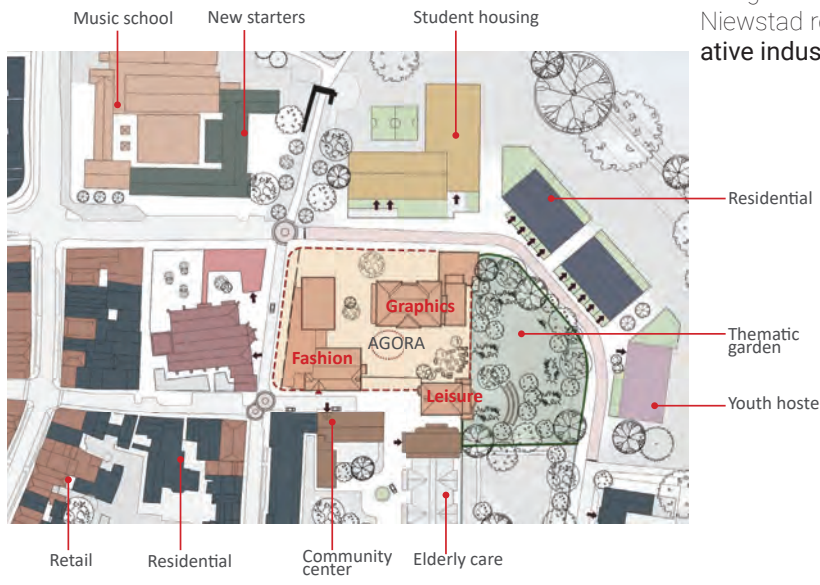
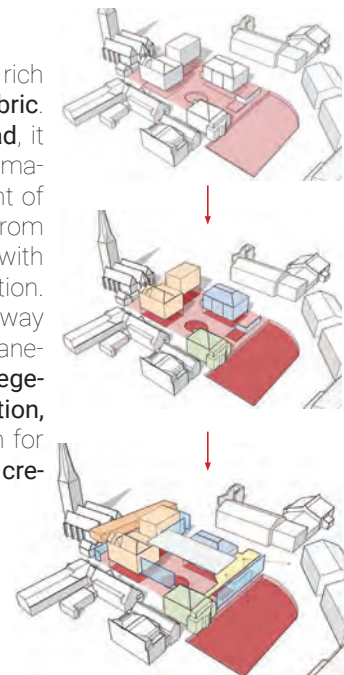

Area of transformation.

New fashion school



Ground floor plan



Upper floor plan



# Educational Agora of Klein Vaticaen.

George Sitarenios.

new era for a school complex



## Agora Canopy.

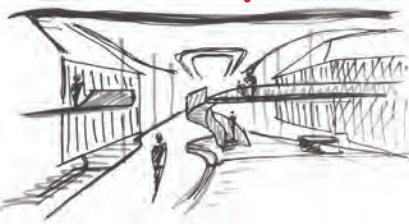

Conceptual sketch - Defining the form

Essential element of the overall design strategy is the **canopy** that will **provide enclosure for the Agora** space. As such we define the area surrounding the 3 transformed buildings, which manages to functionally unite the independent building structures into one whole academic institute. Roofing this space, is essential not only in order to adopt to the **climatic requirements** of the local weather, but also to maximize its flexibility and **ability to host plethora of different activities**, ranging from the needs of school itself to a community related event, like the celebration of national holiday or a casual evening concert. **Architecturally speaking** the canopy is **inspired by the notions of fluidity** and clarity of gesture, aiming in provoking a gentle yet **powerful relation** with the **existing historic structures** that it connects to.

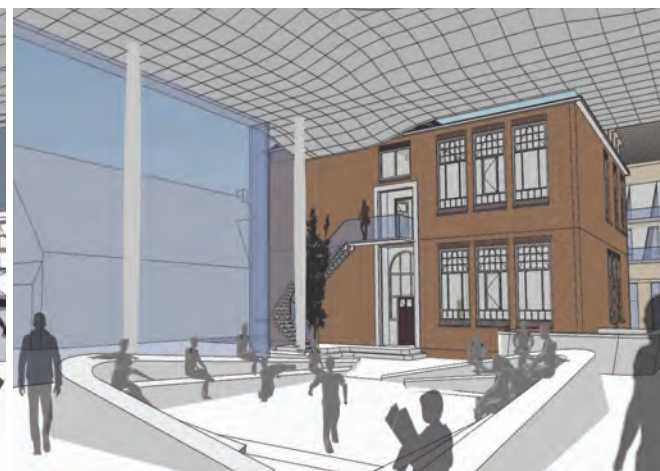
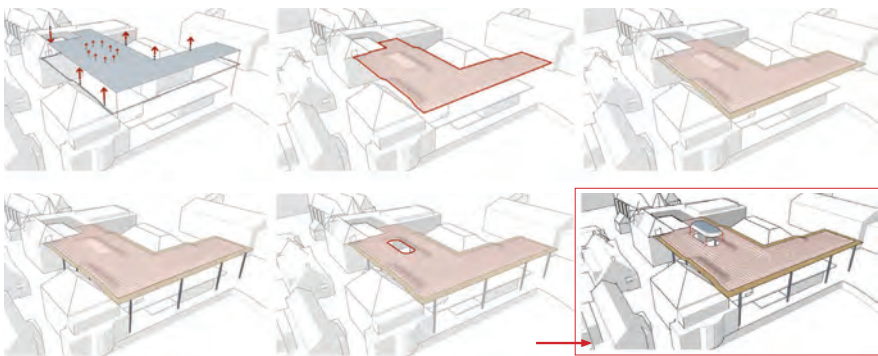



# THE REUVERSWEERD ESTATE

Johannes Düber  
Germany

## transformation concept

### Design Concept:

The main inspiration for my design stems from the great variety of spaces, atmospheres and time layers on site. Preserving this unique quality for the public and making it experienceable as well as using it as a source of revenue is my main focus. I ask the question: **"How can the historic layers of the site be preserved and made experienceable?"** To answer this question I introduced the 3 following approaches:

1. Offer additional programme
2. Preserve the original building fabric
3. Establish new connections

Each approach is reflected in a concrete intervention on site. The site is mainly transformed into a boutique hotel. To attract more visitors and therefore create more revenue as well as to make the site sustainable I introduce a restaurant and market hall in combination with a greenhouse. Located in the former functional post war stables it also functions

as a new public entrance to the site.

A big part of the atmosphere on site is characterised by the war damages in the main house. The core idea is to maintain the original atmosphere of the rooms with only a few "images" of the historic rooms while providing modern living standards. All serious damages to the brickwork are maintained and similar to a showcase, in a museum exhibited through a window pane. This is contrasted by the new plaster wall finish around the frames which is painted in a way that it matches the original colour scheme of the room.

Introducing a walkway which connects all buildings on site serves two functions. Firstly it makes the navigation for visitors much easier and leads them from one function to the other. More importantly, however, it serves as a tool to tell the history of Reuversweerd. Leading from one time cluster to the other it shows the visitor the different time layers and atmospheres. By making a connection that was never there before it also creates an entirely new context for the buildings which enables a focus shift towards their history and spatial qualities rather than their beauty.

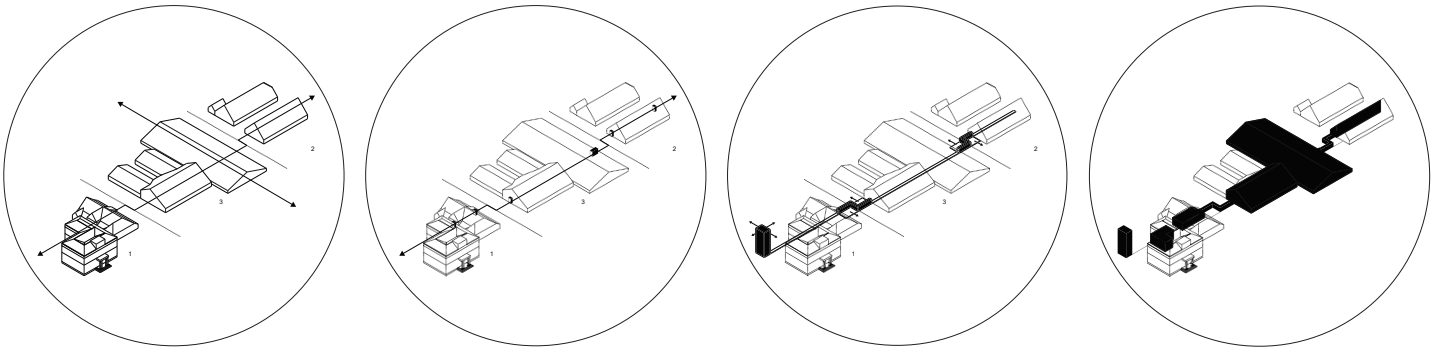

Walkway Concept Diagram

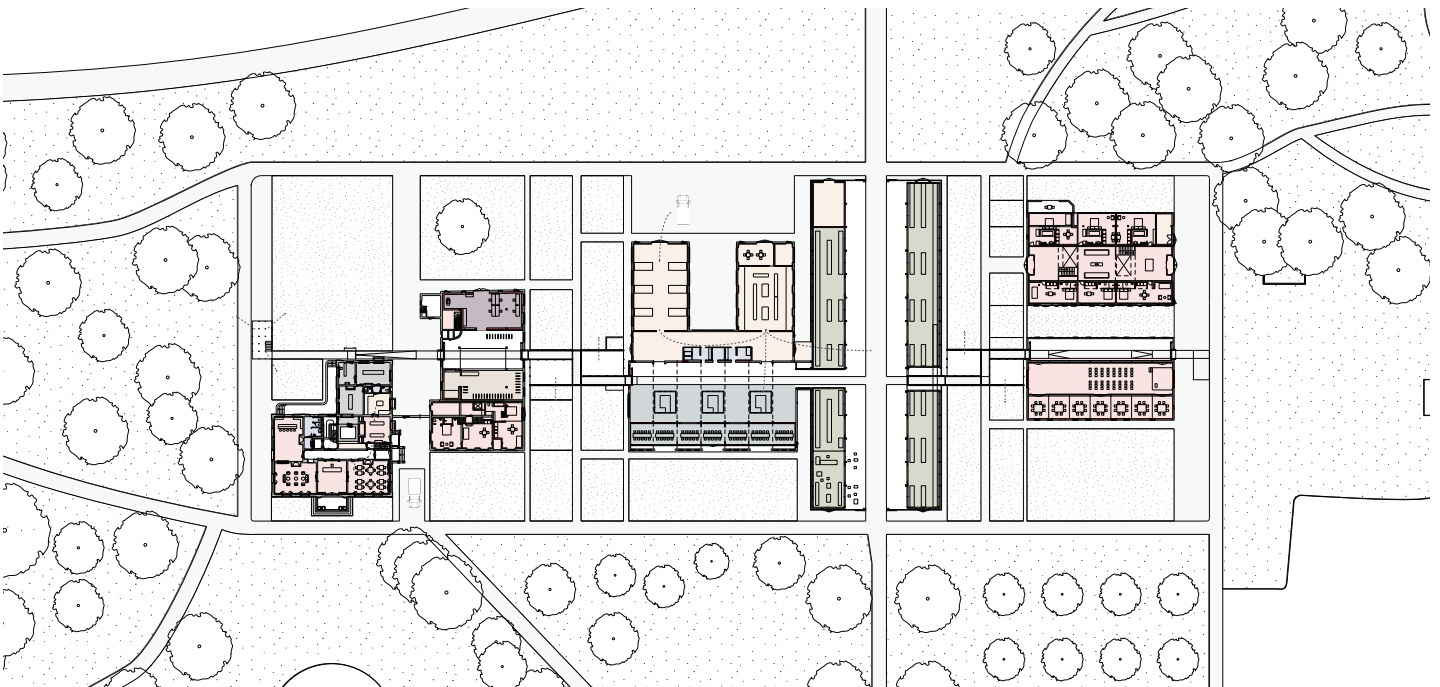

Site Plan 1:500



KEY

<span style="display: inline-block; width: 10px; height: 10px; background-color: #f8d7da; border: 1px solid #c3e6cb;"></span> Hotel, Event Space	<span style="display: inline-block; width: 10px; height: 10px; background-color: #d1ecf1; border: 1px solid #bee5eb;"></span> WC	<span style="display: inline-block; width: 10px; height: 10px; background-color: #d4edda; border: 1px solid #c3e6cb;"></span> Market, Restaurant	<span style="display: inline-block; width: 10px; height: 10px; background-color: #d1ecf1; border: 1px solid #bee5eb;"></span> Walkway/ Museum
<span style="display: inline-block; width: 10px; height: 10px; background-color: #fff3cd; border: 1px solid #ffee58;"></span> Kitchen, Service Area	<span style="display: inline-block; width: 10px; height: 10px; background-color: #d4edda; border: 1px solid #c3e6cb;"></span> Office	<span style="display: inline-block; width: 10px; height: 10px; background-color: #d4edda; border: 1px solid #c3e6cb;"></span> Greenhouse, Shop	<span style="display: inline-block; width: 10px; height: 10px; background-color: #d4edda; border: 1px solid #c3e6cb;"></span> Bike Store/ Rental

# THE REUVERSWEERD ESTATE

Johannes Düber  
Germany

## transformation concept



WD frames interior perspective



WD frames north-east facade elevation

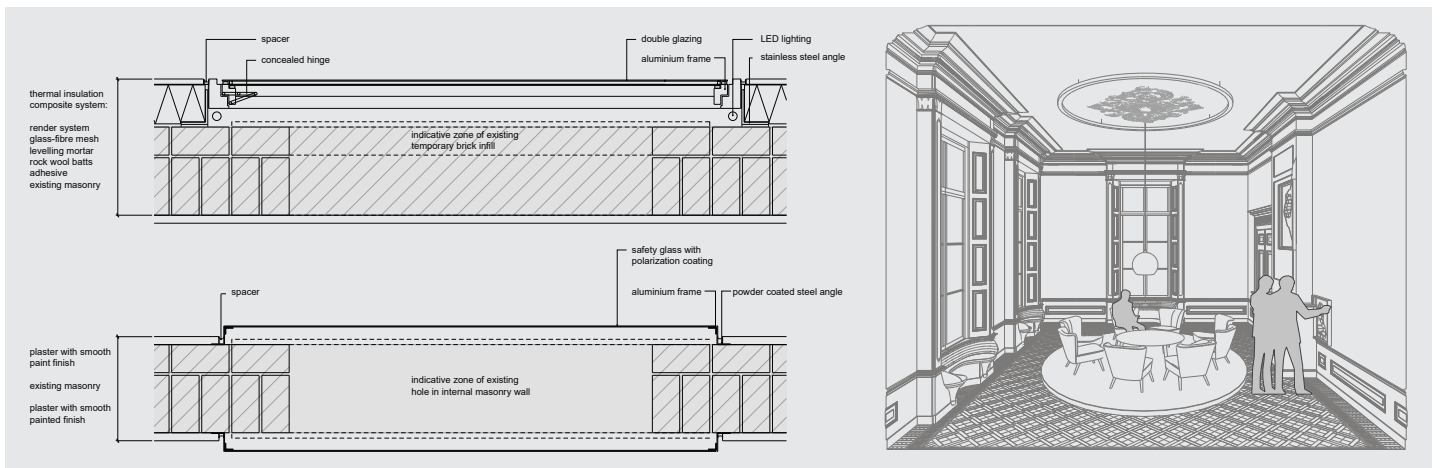

WD frames Detail 1:10 and interior perspective



Walkway pavilion perspective



# REUVERSWEERD

## an equine business

Thomas Bianchi  
Netherlands

### Reuversweerd as an equine breeding farm

My proposal for Reuversweerd is a function it originally used to have in the early 20th century, a horse breeding farm. After the attacks of WWII and the vacancy of the buildings since several years, the entire estate has been in decay. My proposal aims to give back a functional reuse to the buildings and the plot in order to ensure a sustainable and feasible redevelopment. My plan reinstalls the functional versus representative dynamic between the buildings while also emphasizing the original and new time layers of the buildings in their expression, materials and spatial experience/function. The new building, an indoor riding facility, is the center of the functional cluster housing an important function for the business. It visually ties the cluster together by reacting to the surrounding barns and stables, following their color scheme, façade characteristics, and shape.

While blending in, the arena shows it's a new intervention through its modern material usage such as its wooden construction and façade and simple steel roof. Value levels of the different buildings and their interiors vary largely and I'm proposing an intervention strategy that deals with these differences. The main house has the highest value and is repurposed as an office and reception for the guests. The highly valued war damages in the interior are being preserved and displayed in a way that adds extra quality to the spaces. Frames are being placed around them to emphasize them in their original condition. Similar frames are proposed in the existing stables and barns but are executed more boldly, ensuring functionality over preservation. These interventions give the existing buildings and plot a purpose again, befitting their current spatial quality and heritage values.

emphasizing original dynamic

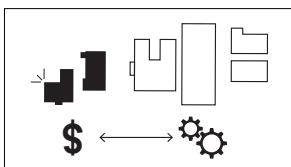

reinstalling functional reuse estate

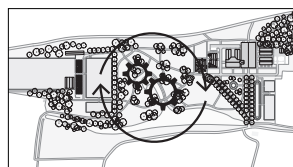

intervention strategy various values

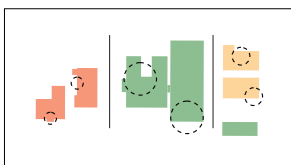

emphasizing visible time layers

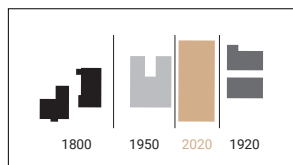

starting points design

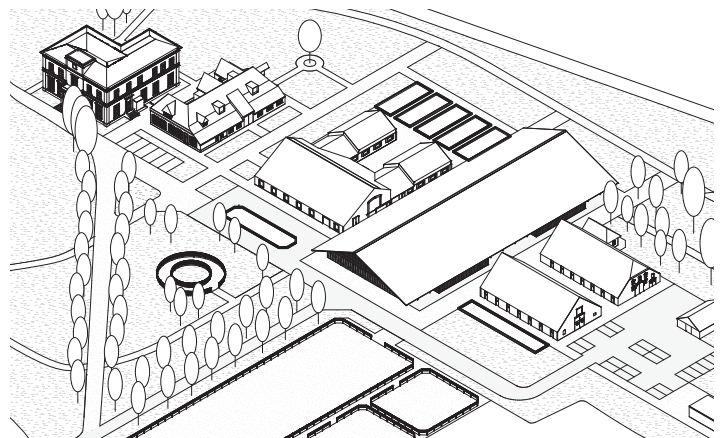

isometric overview



- Reception
- Office spaces
- Living spaces
- Sanitary/toilets
- Multi-functional space
- Nursery
- Paddock/riding pit
- Breeding facilities
- Guest lounge/facilities
- Stalls
- Horse facilities (tack, grooming etc.)
- Washing facilities horses
- Services/storage spaces
- Circulation

functions building ensemble 1:500

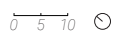



# REUVERSWEER

an equine business

Thomas Bianchi  
Netherlands



visualisation representative cluster



interior salon main house

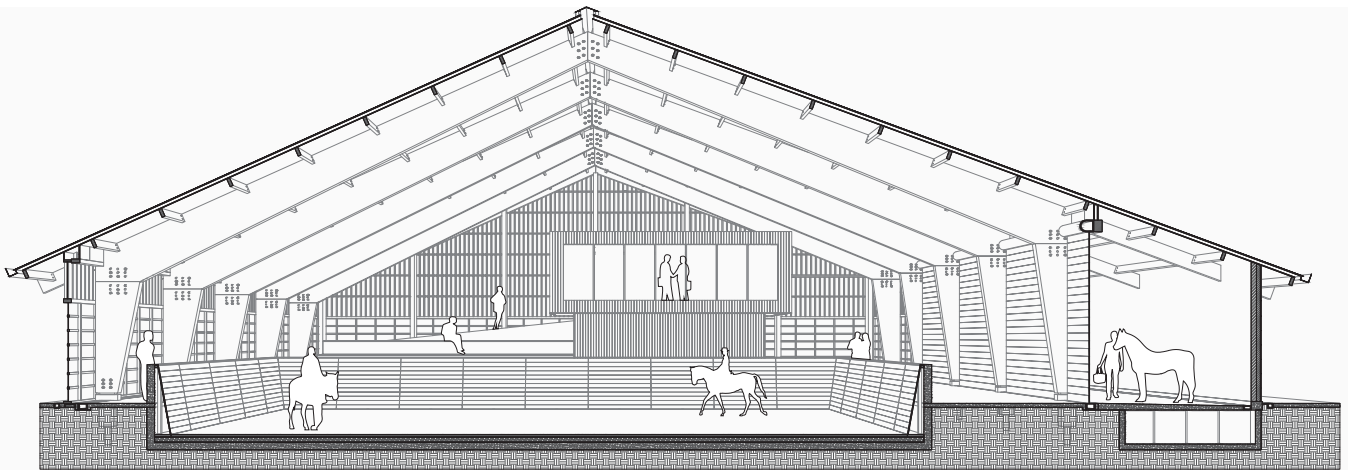

3D section arena



visualisation functional cluster

## A unique event location

### Reuversweerd: event location with hotel

The site currently has no function and the buildings are vacant. The manor house, which is also a national monument, has not been used intensively since it was abandoned after WOII, also the quality of the building is deteriorating. There are many buildings on site, all of which have had different functions. The manor house is not unique in the region, in addition the location is very remote and there are few passersby.

My idea for a new program is to introduce an event location with hotel rooms. The different events which could be held on site are: weddings, meetings, congress, parties, activities and other events. Reuversweerd should be a destination on its own. Focused on the higher class, to create enough revenue. A big hinterland is needed, because of the remote location of Reuversweerd.

The main concept for the redesign consists out of 3 goals: continue the story of Reuversweerd, remain the values and enhance them, show the time layers of the site.

The orangery will be used for the owner and energy production and storage. The ensemble will be used for the events. By placing 3 new buildings on site the estate gets a new identity. All the buildings will have specific functions in them, so visitors will use the entire site during their stay at Reuversweerd. They are also all different, which will contribute to the unique experience visitors will have at Reuversweerd.

What makes Reuversweerd unique is the combination of the representative atmosphere and the rural farm, which will also be visible in the new design. Besides that, the buildings will also show the different time layers present on site.



A big hinterland is needed

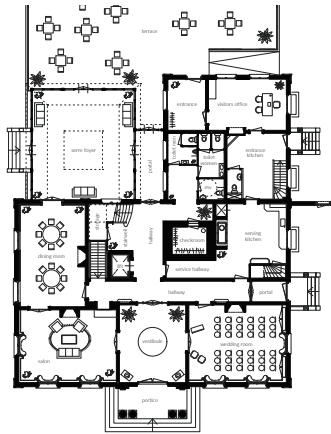

Ground floor plan main house

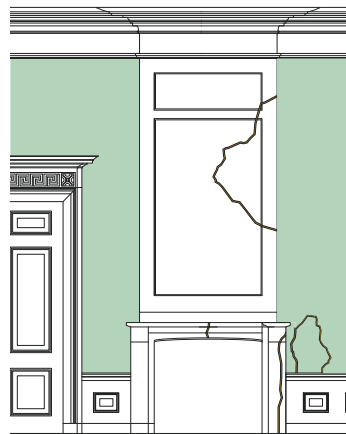

Interior with 'war damage'

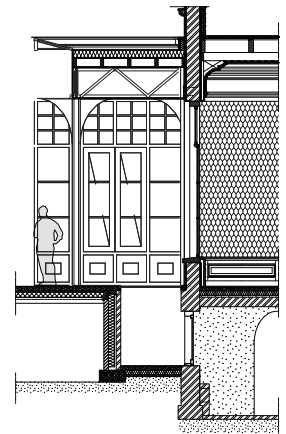

Detailed section of main house

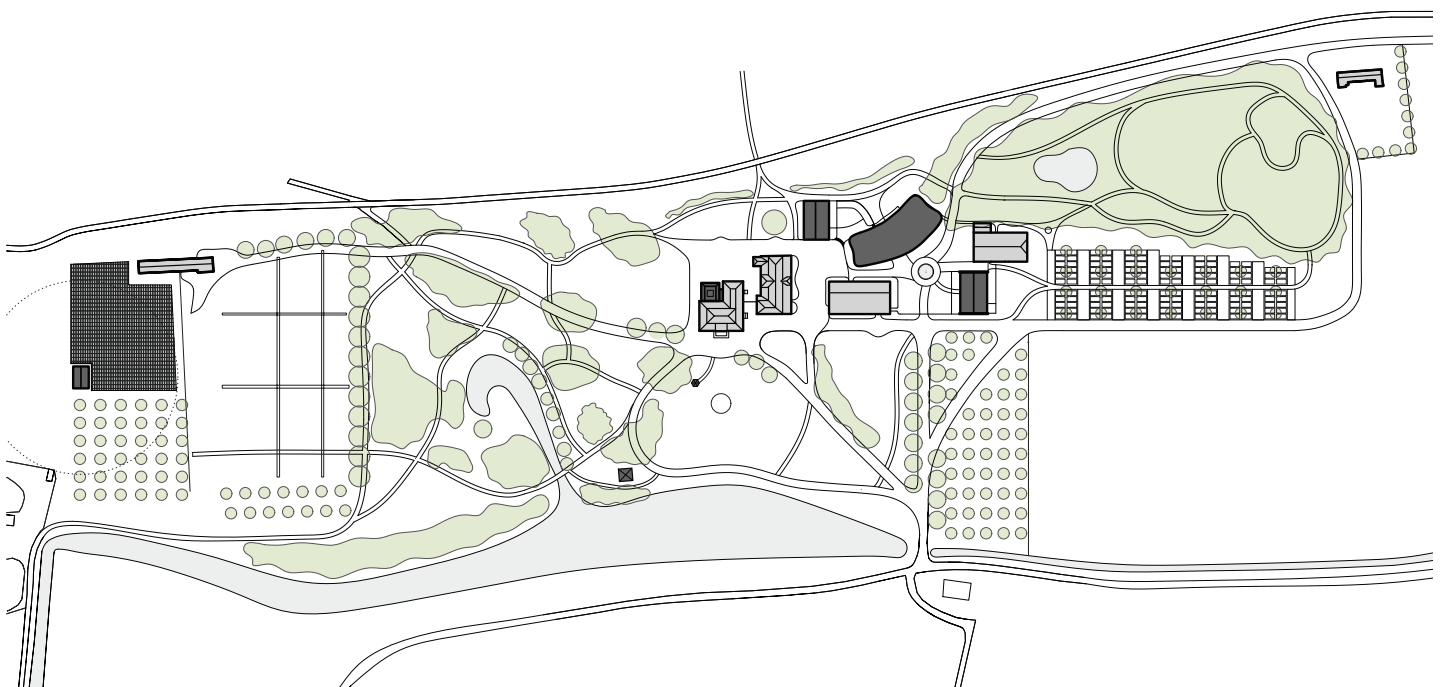

Estate plan



# REUVERSWEERD

Youri Slaghekke  
Netherlands

A unique event location



Impression of the new extension of the 'main house'



Impression of the transformation of the 'anchor barn'



Impression of the estate from the Piepenbeltweg



Ensemble plan



# STRUCTURES OF DURABLE NEIGHBORHOOD

Lin Yang  
China

## Neighborhood in Presikhaaf

### Introduction:

Presikhaaf is a neighborhood planned by the idea of CIAM, which is completely functional. Presikhaaf I is the oldest part of the whole neighborhood and occupied by dwellings. According to the site visit, the courtyard block in Maaslaan street is a uniform and isolated neighborhood. It looks like this neighborhood has its own territory and they lack connection from different scales. This block is totally equal from the layout to each unit, while the different color applied to the facade shows the wish of identity.

I want to achieve a durable neighborhood in several aspects:

1. Give Identity: The identity of their living environments could contribute to the durable neighborhood.

2. Enhance Social Cohesion: Since this neighborhood gathers lots of immigrants, if they could meet their neighbors in collective space and have more connection with the inner courtyard, it works for a durable neighborhood.

3. Be Willing to Stay: Extension of the balcony could give more space to residents and improve their living conditions. So that fewer people will move and less problematic for a stable community; Also a lively playground could work for a durable neighborhood.

4. Material and Construction: Steel structures look lightness; And it could be modular and removable; Material that easy to maintain is sustainable; Choose recyclable steel and wood is also durable.



Views

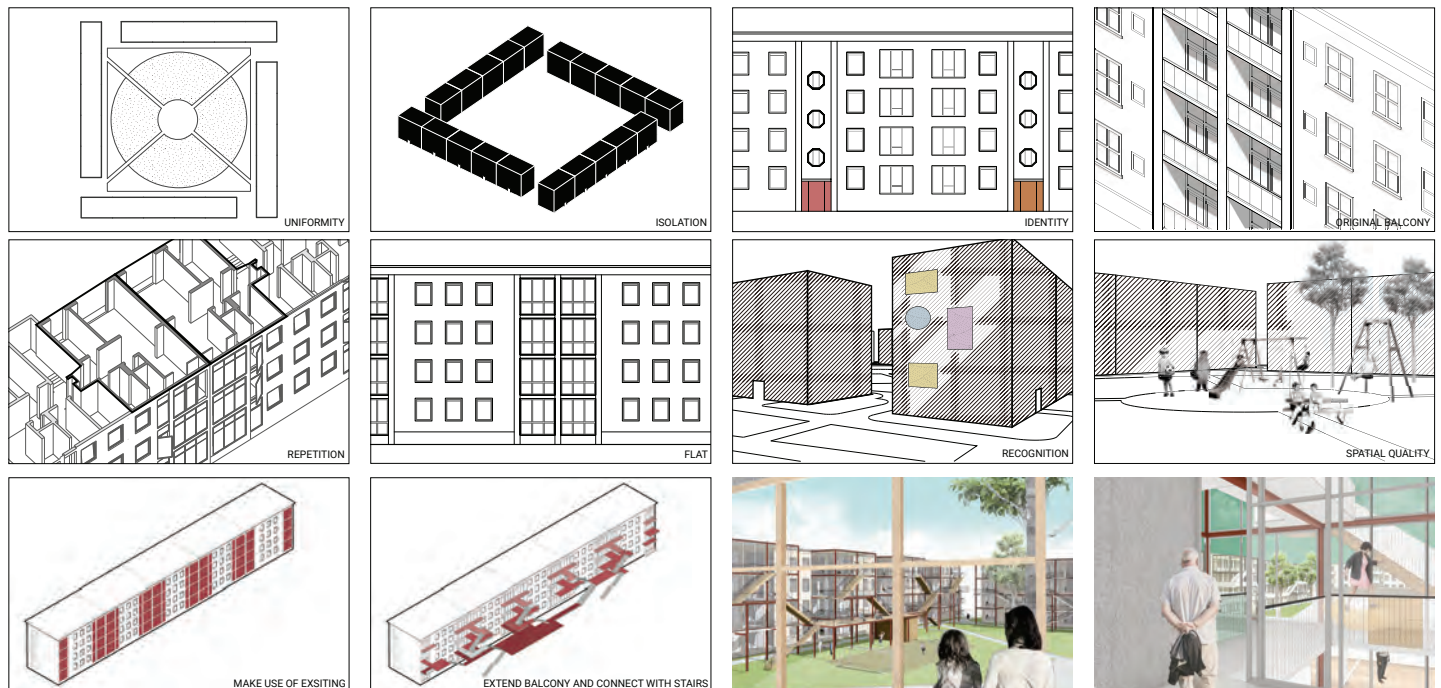

Design Ambition & Strategy





# STRUCTURES OF DURABLE NEIGHBORHOOD

Lin Yang  
China

## Neighborhood in Presikhaaf



Masterplan

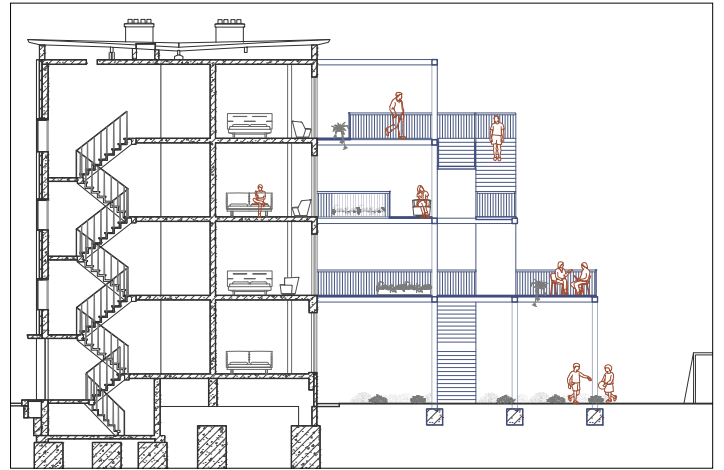

Section 1:100

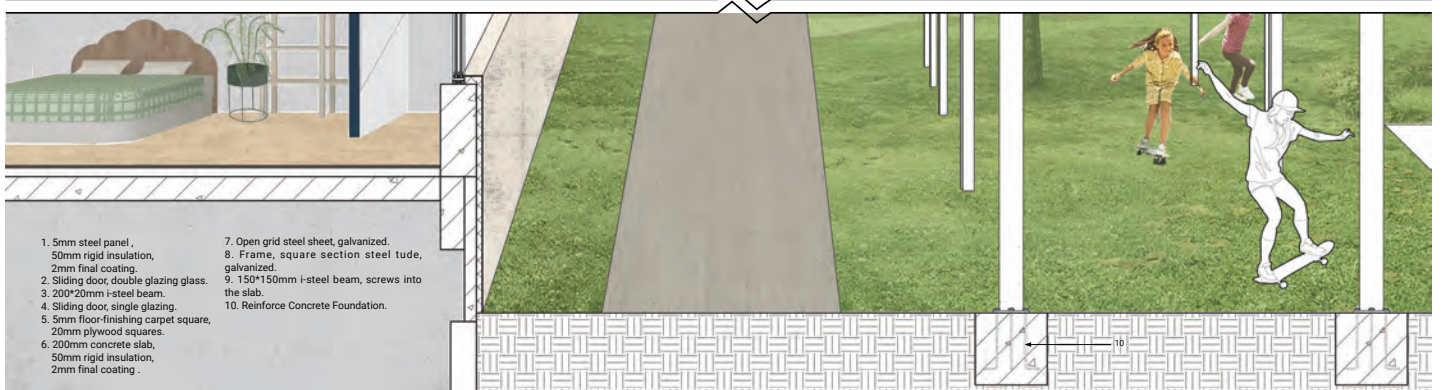

Detail Section



# IS THIS MY CHURCH?

## Walburgiskerk - Arnhem

Rada Ruijter  
Netherlands

The subject of this design is the Walburgiskerk in Arnhem. This church has lost its original function for some time, and is currently in use as an exhibition space for the Museum of Arnhem. The aim of this project is to transform this church into something that is still relevant in contemporary Arnhem. On the other hand, existing values of the church should be taken into account; they need to be maintained and accentuated as much as possible. It offers great spatial qualities, situated in a secluded plot that is shielded off from the rest of the city by other buildings. It has varied spaces, that differ in size, height and expression, ranging from large, public spaces to smaller, more private spaces, spaces right at the city's centre.

This project aims to incorporate the existing spatial diversity and the original sense of collectivity with modern demands: flexibility and the choice to seclude oneself from others. The new function will include a range of work and leisure spaces of different characters, from collective to very secluded and private. For a small sum per month, one can subscribe to get access to most of the work and leisure spaces, whilst some spaces can be rented separately.

The design consists of several parts with different characters. The most collective space lies at the heart of the church and it consists of a large staircase along the central axis. The sizes and shapes of the steps define the function; it can be used as a stand, a space to work or to relax. On top of the staircase, in the gallery of the church, work and leisure spaces are slightly more secluded, connecting to a private terrace on the southside.

Underneath the staircase, the spaces are more private. Although they are still connected to the heart of the church through the construction of the staircase, the glass between the steps limits the influence of sound. On the southside, this private zone is connected to the former chapels of the church, which can now be rented as private meeting spaces. The former sacristy on the northside transitions into the private patio, where the ground level is lowered by 2,5 metres, which gives the space a more enclosed, private character. It also exposes the foundations of the former expansions of the church, to show that the current shape of the church is not a given fact, but the result of a long series of adjustments and interventions.

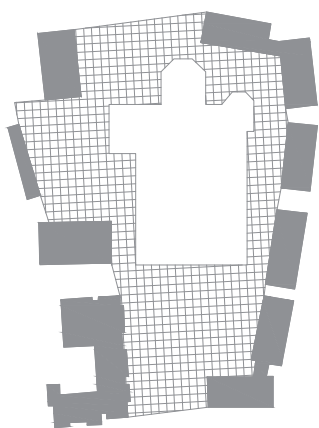

situation: secluded

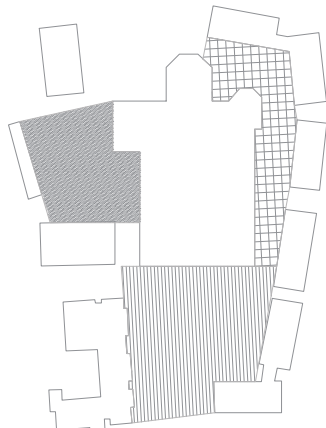

situation: different characters

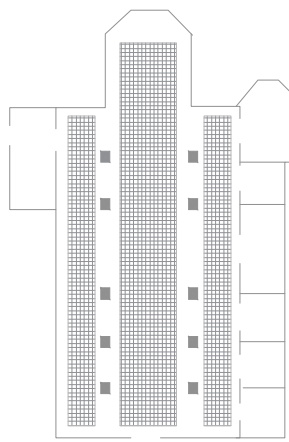

structure: three parallel axis

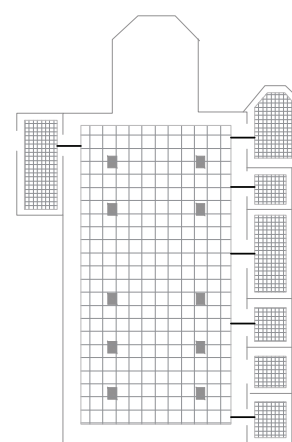

structure: hierarchy of spaces

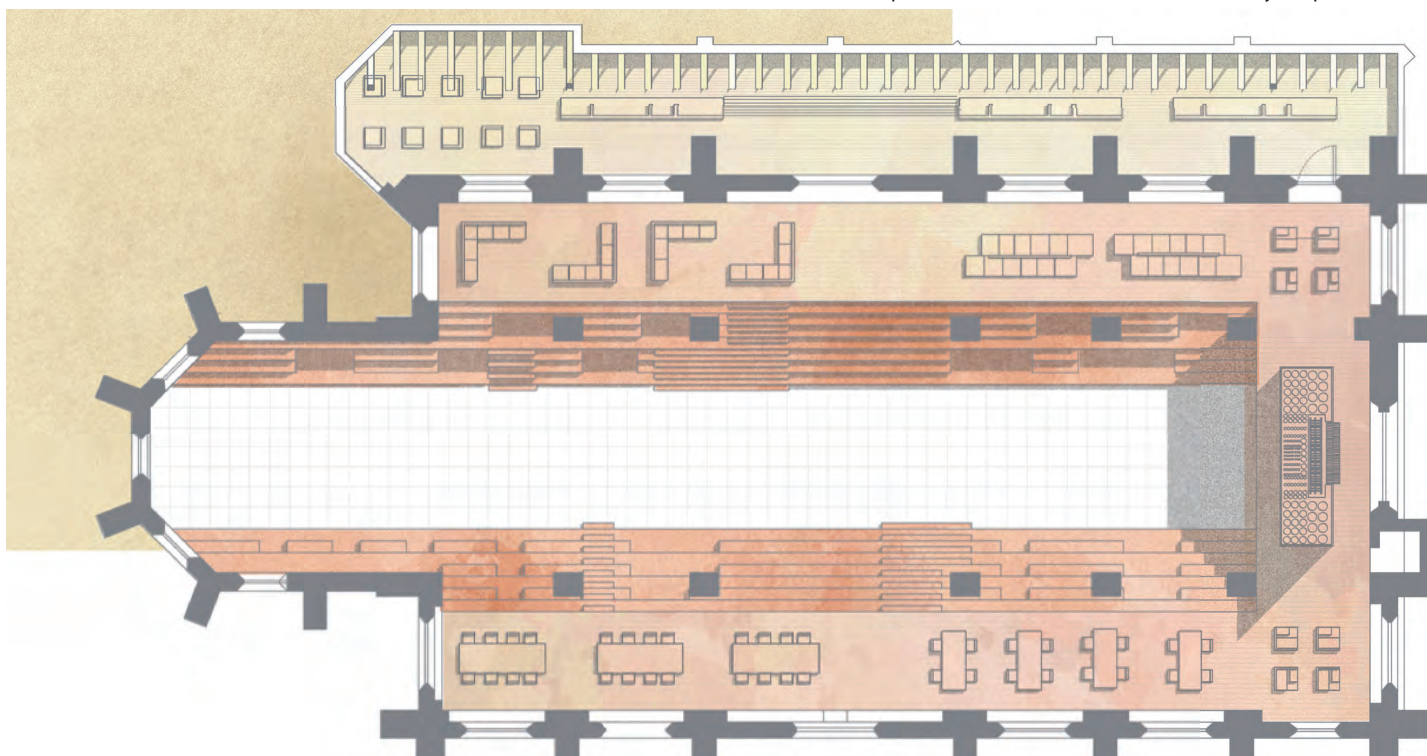

floor plan: collective central axis, staircase, gallery workplaces and terrace



# IS THIS MY CHURCH?

Walburgiskerk - Arnhem

Rada Ruijter  
Netherlands



1



2



3



4



5

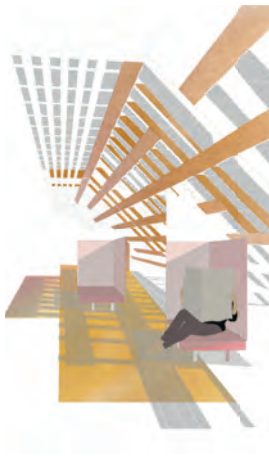

6



7



8

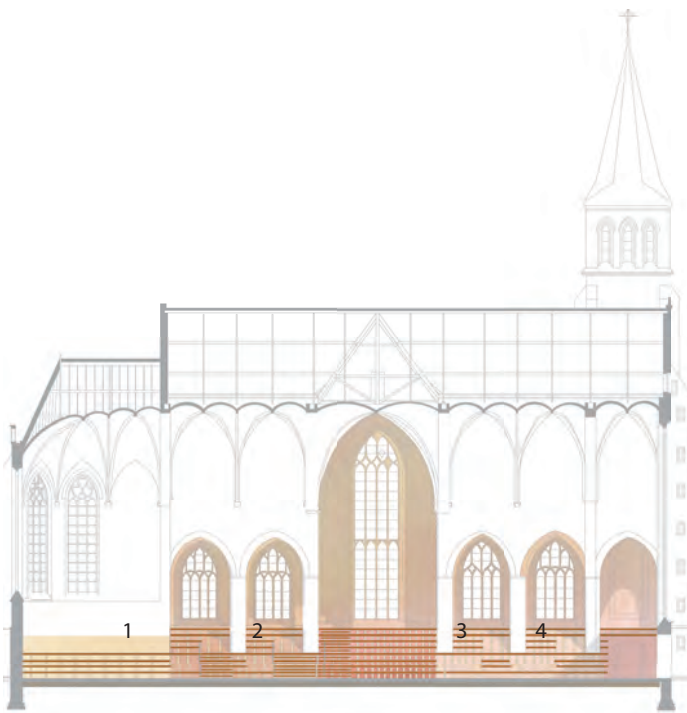

1

2

3

4

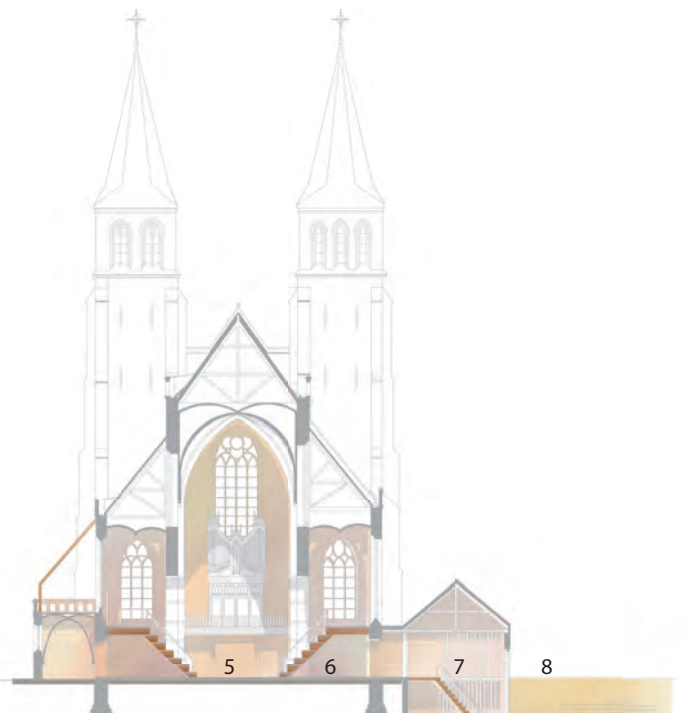

5

6

7

8

sections

# SYMBIOSIS

Ariane Zwinkels  
The Netherlands

## working together horizontally and vertically

### Why symbiosis?

The church is situated in the middle of a valuable urban context. As is shown in the diagrams below, there are three values that pop out: the three different zones in the surroundings: leisure, social and active space; the open and the hidden character of the different churches; the different zones in the direct surroundings of the church: garden area, junction area, courtyard area, calm semi-private area. The church is perfectly in the middle of the three different urban zones. To enhance these values all these zones will be represented in the direct surrounding of the church. By doing this the church site can function as a junction between the three different urban zones, but remain their own character. There will be a leisure church garden, a more active courtyard and the church itself has the social character represented in its functions. A new routing connects

the park with the church site to the city core. The church site will function as a place of rest on this connection. On the ground floor there is an indoor market. Horizontally this market is connected with the church garden, and the market square in front of the church. Then on the split level above the main entrance, where the organ is situated, there is a bar the 'drankorgel'. Visitors can get their drinks here and sit upstairs in the church cafe. The idea behind this cafe is that you can buy your drinks here but are free to bring your own food. This food could be bought in the market below for a fair price. This is where the vertical symbiosis is arranged. In the towers and the attic above the vaults groups of people can come for beer tastings. The church always stood in the middle of society because of its religious function. The symbiosis and the new functions tries to preserve this social role in society.

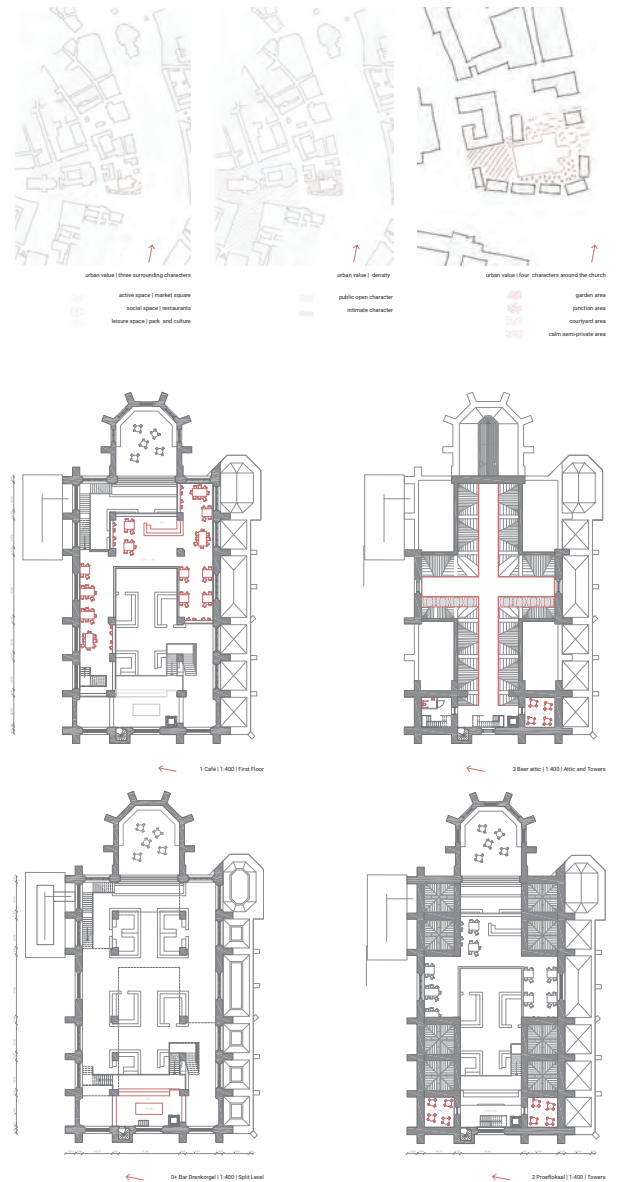
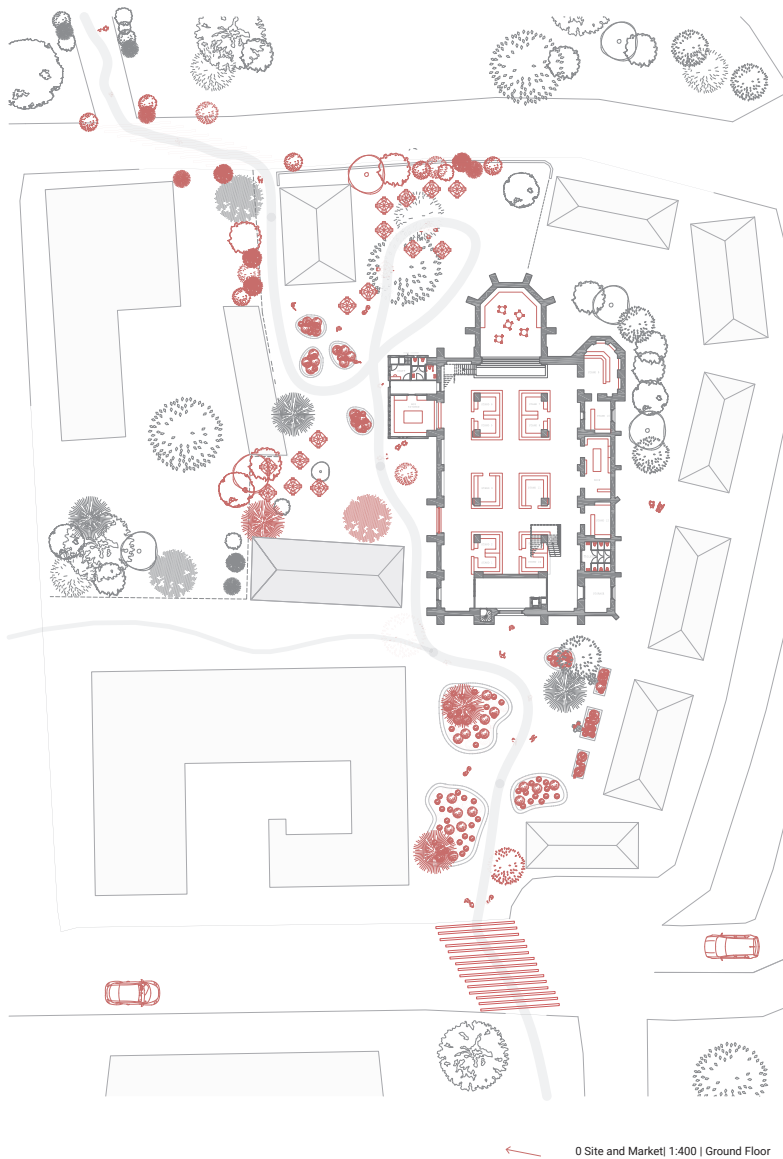

image





# SYMBIOSIS

Ariane Zwinkels  
The Netherlands

working together horizontally and vertically



Impression Market | Ground floor



Impression Cafe | First floor



longitudinal section | north to south



impression | proeflokaal in tower

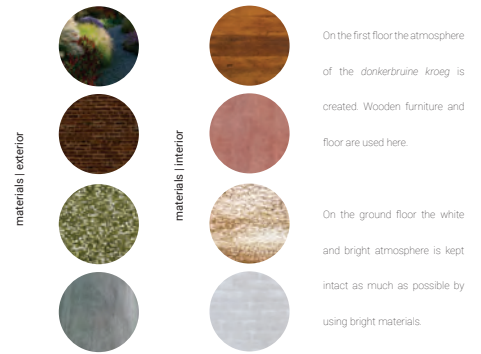

impression | attic

## vertical symbiosis

proeflokaal  
speciaalbieren  
to reserve for groups of  
people | attic and towers

proeflokaal en  
corridor | towers

dark brown cafe where  
you can order the drinks  
at the organbar and if  
you want to eat, get it  
from the market for a  
supermarket price | first  
floor

organ bar | split level

market with grocery  
food, but also readymade  
dishes besides a salumeria and  
a supermarket floor



longitudinal section | south to north

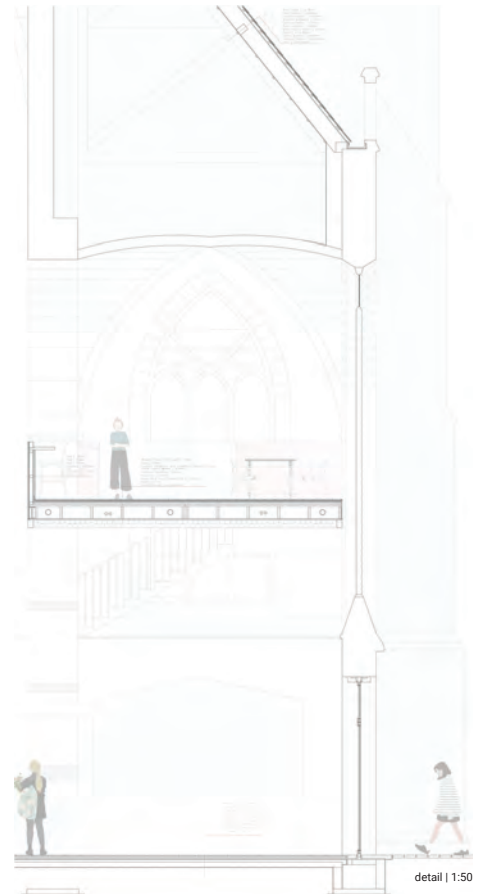

# ST.MAARTENKERK'S EXTENSION-

## MEDITATION BETWEEN TOPOGRAPHICAL EDGES AND SURFACE OF TIMES

Hui Wing Hei Joanna  
The Netherlands

That the church is bounded by greenery and water which gives secluded atmosphere and at the same time alienate it from the city centre among the tranquil landscape. The project aims to dissolve the topographical edges of the site, activate the underused liturgical building, preserve and restore the existing building in its full glory, in its entirety, despite it being heavily affected by the ravages of time. Tiel is home to a rich mix of ethnicities and working class that work in larger cities nearby. New major programmes including a market hall and visitor center are introduced to transform the church back to a public focal point, trigger cultural sharing between amateurs and trigger local economic opportunities for youth start-ups. The church possesses the qualities of a major structural urban element. The extension adds a contemporary layer to the inhomogeneous composition resulting from the continuous construction and deconstruction over times and makes the history of the church more integral, visible and readable. The new programmes make the historical

and religious site spirited once again. The ethereality of the new glass pavilions and market hall extension present a relaxing and soft design that characterizes the indoor liturgical area. The visitors move back and forth across spaces, between the constant evolving of bare nature, the extant and new architectural intervention. For example, the visitor centre grows into the history archive which was once the consistory. It also contains the archeology interpretation area where the foundation and rubbles of the site are fully revealed. Glass is wrapping the spaces forming continuous elevations, uninterrupted by corners. The canopy that hovers is finished with mirror-polished stainless steel and supported by slender pillars. Its polished surface reflects the surrounding greenery, canal and materiality of the brickwork. This dematerialization with the use of glass and stainless steel adds a contemporary layer to the site without competing with the original.



Urban response



Landuse and function



Inactive edge condition

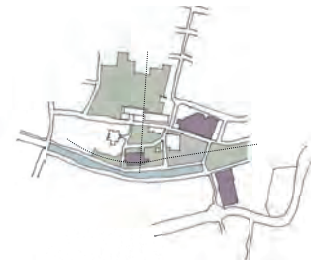

Knitting blue and green system

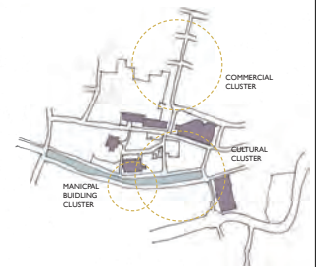

Programme relevance and potential new city center



Continuity of time & complementary composition

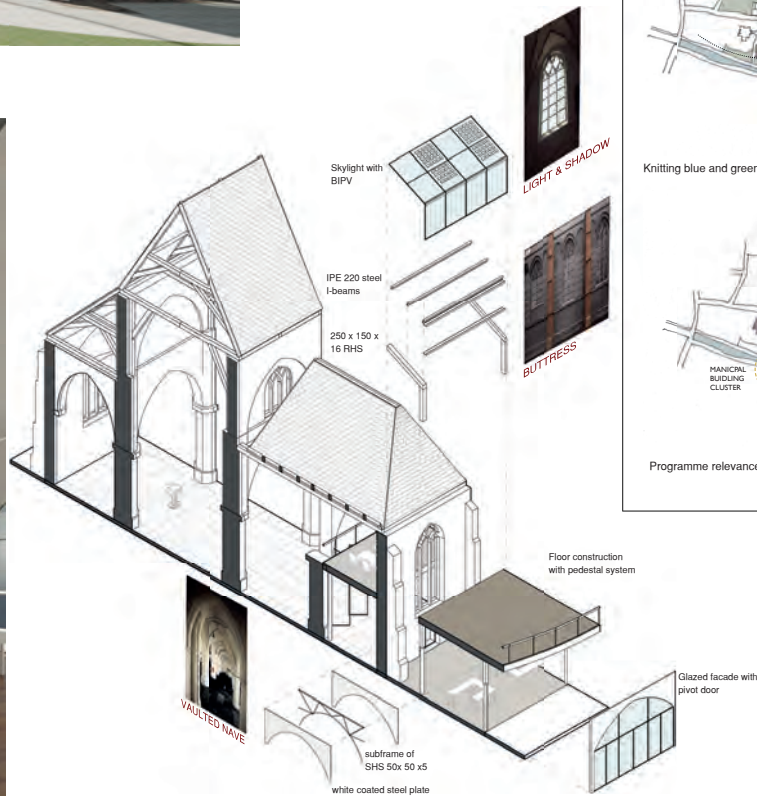



# ST.MAARTENKERK'S EXTENSION-

## MEDITATION BETWEEN TOPOGRAPHICAL EDGES AND SURFACE OF TIMES

Hui Wing Hei Joanna  
The Netherlands



Aerial view

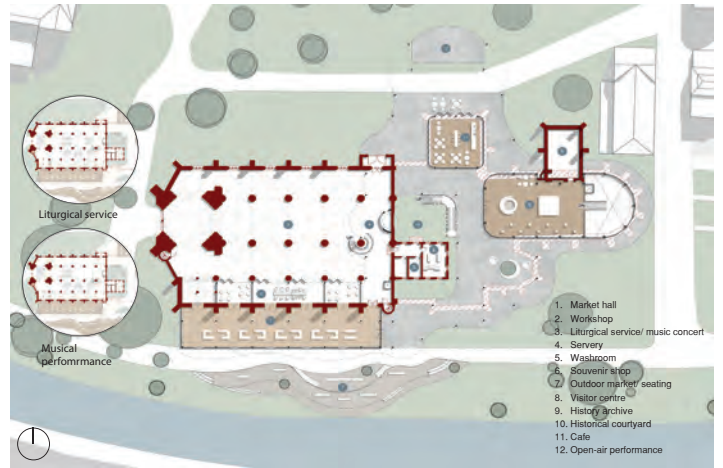

Ground floor plan

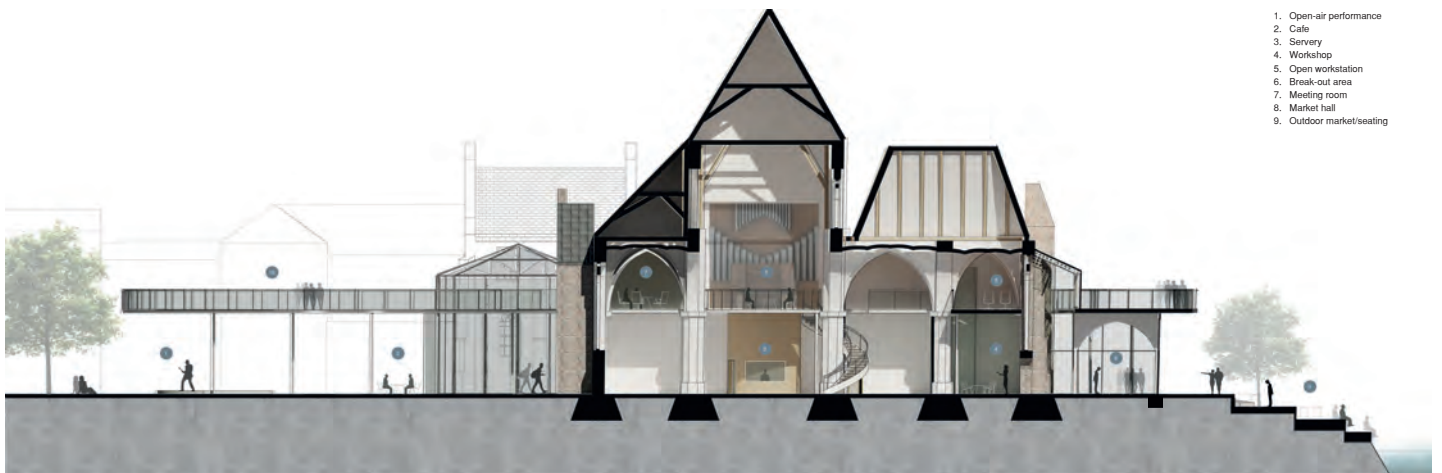

Transverse section

1. Open-air performance
2. Cafe
3. Senvary
4. Workshop
5. Open workstation
6. Break-out area
7. Meeting room
8. Market hall
9. Outdoor market/seating

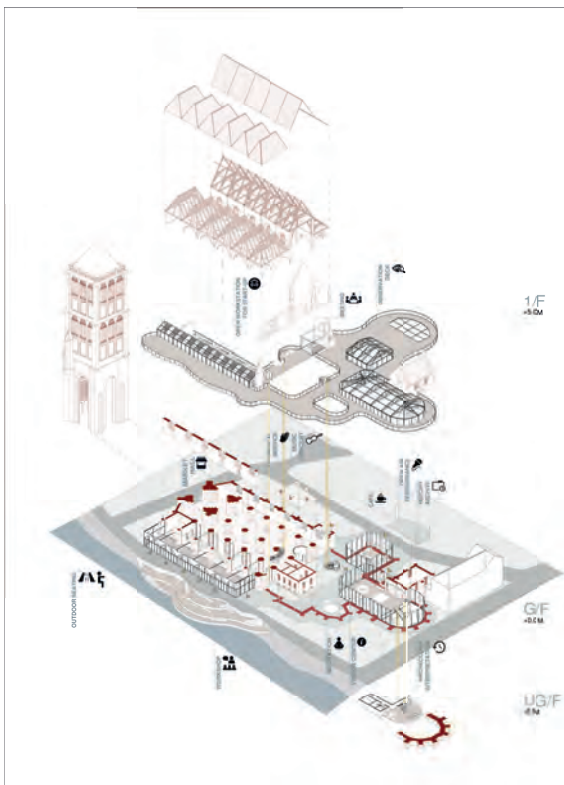

Exploded axonometric - function & circulation



Observation deck



Liturgical service/ music concert

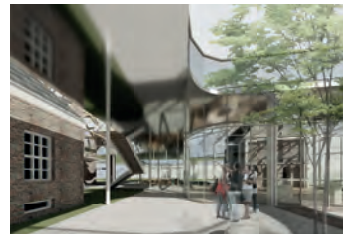

Free-flowing circulation



Market hall/ outdoor seating



Workshop

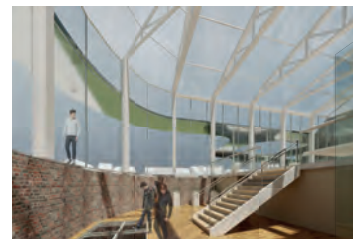

Archeology interpretation

# SINT MAARTENSKERK

Sofia Montalti

Italy

## The new city centre of Tiel

### City Strategy and Opportunities

The city is defined by one economic cluster, which represents the main shopping streets, and by one cultural cluster, which groups together a cinema/theater, a library, a museum and two churches. Sint Maartenskerk is located in a strategic position: it is located in the centre of the cultural cluster and it is easily accessible from the city centre. However, it has a scarce connection with its surroundings, which need to be activated and revitalized. Even though the area is very fragmented and disconnected, there are many opportunities to develop it. The urban strategy connects the two clusters by activating the area around the church with new activities and also by reinforcing the green route that goes around the city together with the relation with the water. The liveability of the big parking lot located in front of the east side of the Church has to be improved and reinvented.

### From Verticality to Horizontality

The existing Church is closed to the inside without any visual connection with the surroundings. The aim of the project is to open the space to the outside by opening the gothic windows till the ground. The green house and the new addition of the sacresty help the existing having a strong relation with nature. The new project for the Church brings new activities by introducing new functions in the area. The Church itself becomes a Gourmet Food Market with different food stands and a café in the interior zone, while, in the southern part, a greenhouse is added to create a pleasing relaxing section with plants and vegetable gardens on the first floor. The remaining sacristy of the old gothic church is transformed into a workshop space with a glashouse extension, where particular classes are instructed (food classes, recycle classes, ...).



Visualizations



Visualization \_ Cross axonometric section





# SINT MAARTENSKERK

Sofia Montalti  
Italy

The new city centre of Tiel

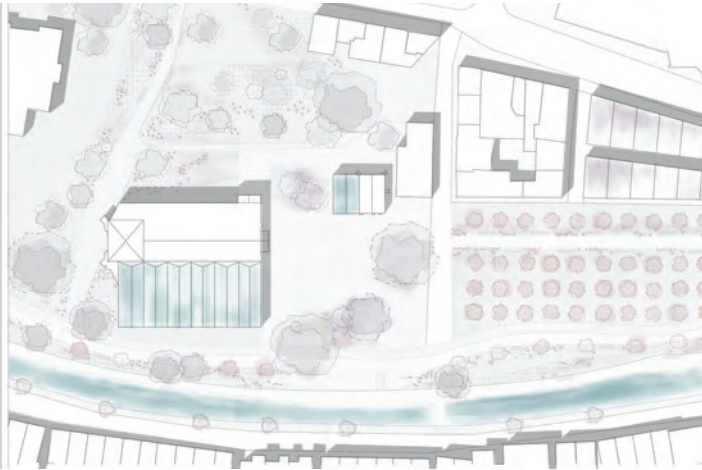

Masterplan



Groundfloor

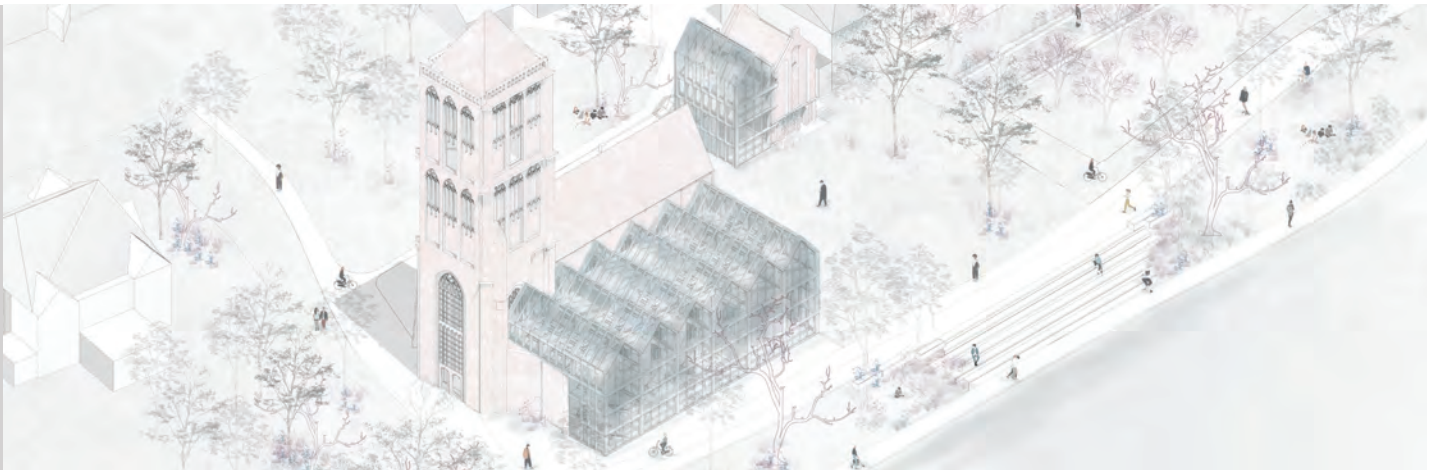

Visualization \_ Church south side with extension and connection to the canal



Southern Elevation

# NIEUWSTADSKERK

## The Point of Interest

Joost Joosse  
Nederland

Het gebied Nieuwstad heeft twee gezichten. Enerzijds een hoge bebouwingsdichtheid en aan de andere kant een grote hoeveelheid aan openbare ongedefinieerde ruimte. In mijn optiek, hebben deze openbare ruimtes waarde en kansen in het creëren en stimuleren van collectiviteit, het samen zijn en meer levendigheid. Op dit moment sluit de kerk zich af van deze openbare ruimte. Bovendien functioneert het plein aan de parkzijde als een parkeerplek. Gezien de mogelijkheden en waarden die dit plein kan hebben is dit een punt van ontwikkeling. Om die reden heb ik mijn ontwerp gericht op het activeren van deze openbare ruimte. Voor de compositie van de uitbreiding heb ik het idee van de 'twee gezichten' geïntegreerd in het ontwerp. Enerzijds een publieke functie die open staat naar het park en de Isendoornstraat. En aan de andere kant een uitbreiding die meer privaat is, aansluitend op de directe omgeving, en dit ook uit door meer geslotenheid. Deze uitbreiding fungeert als het kantoor van

de parochie. Flexibele werkplekken, vergaderruimtes en een archief wat in connectie staat met de kerk, zijn geïntegreerd in de private interventie. De publieke functie heb ik het culturele centrum genoemd. Deze extensie functioneert als een soort dorps huis, geschikt voor ontmoetingen voor zowel de parochie als voor het publiek. Denk aan workshops, activiteiten, samenkomst voor het educatieve centrum rondom Nieuwstadskerk. Daarbij is een kapel toegevoegd als secundaire kerkruimte, wat efficiënter en 'groener' is voor een kleiner publiek. Door deze interventies wordt het plein geactiveerd. Dit schept mogelijkheden voor een nieuwe entree aan deze zijde van de kerk. Daarnaast wordt door het toevoegen van groen en de aanleg van een terras dit een geschikte omgeving voor een bruiloft en dergelijke gebeurtenissen. Kortom, de interventies geven de parochie een nieuwe rol in het samenbrengen van de bevolking en het activeren van het gebied Nieuwstad. Een nieuw punt van interesse voor Zutphen.



Nieuwstad, Zutphen

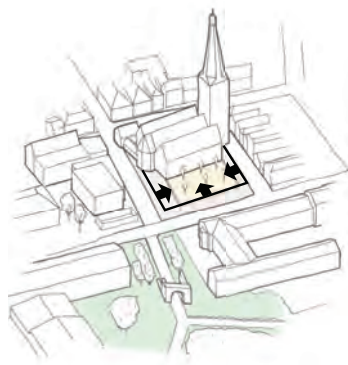

Afgebakend van openbare ruimte

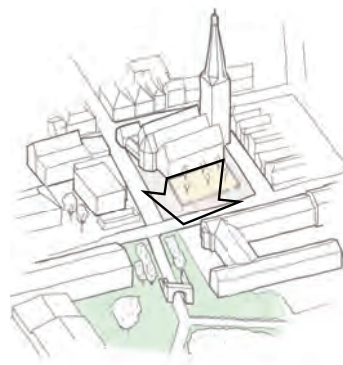

Open naar park

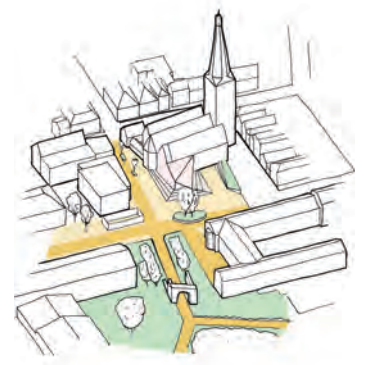

Publieke ruimte activeren

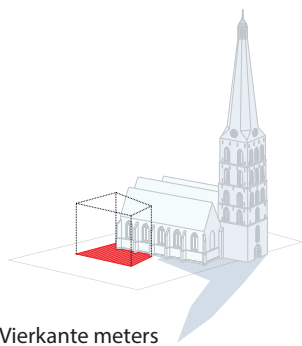

Vierkante meters

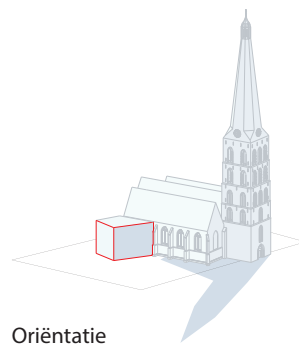

Oriëntatie

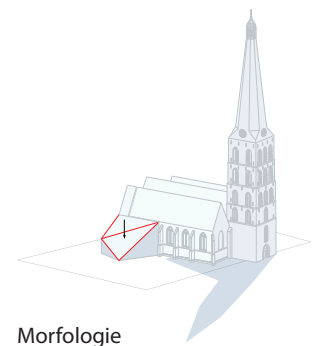

Morfologie

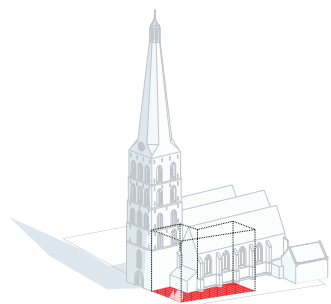

Vierkante meters

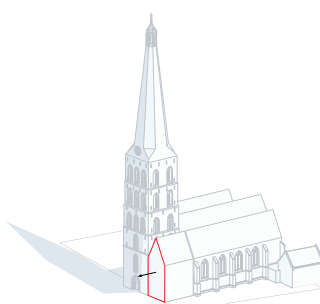

Oriëntatie

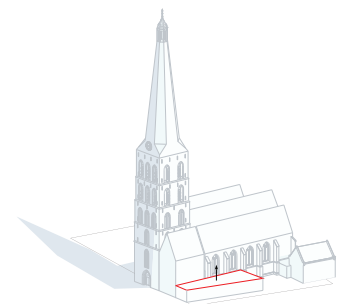

Morfologie



# NIEUWSTADSKERK

## The Point of Interest

Joost Joosse  
Nederland

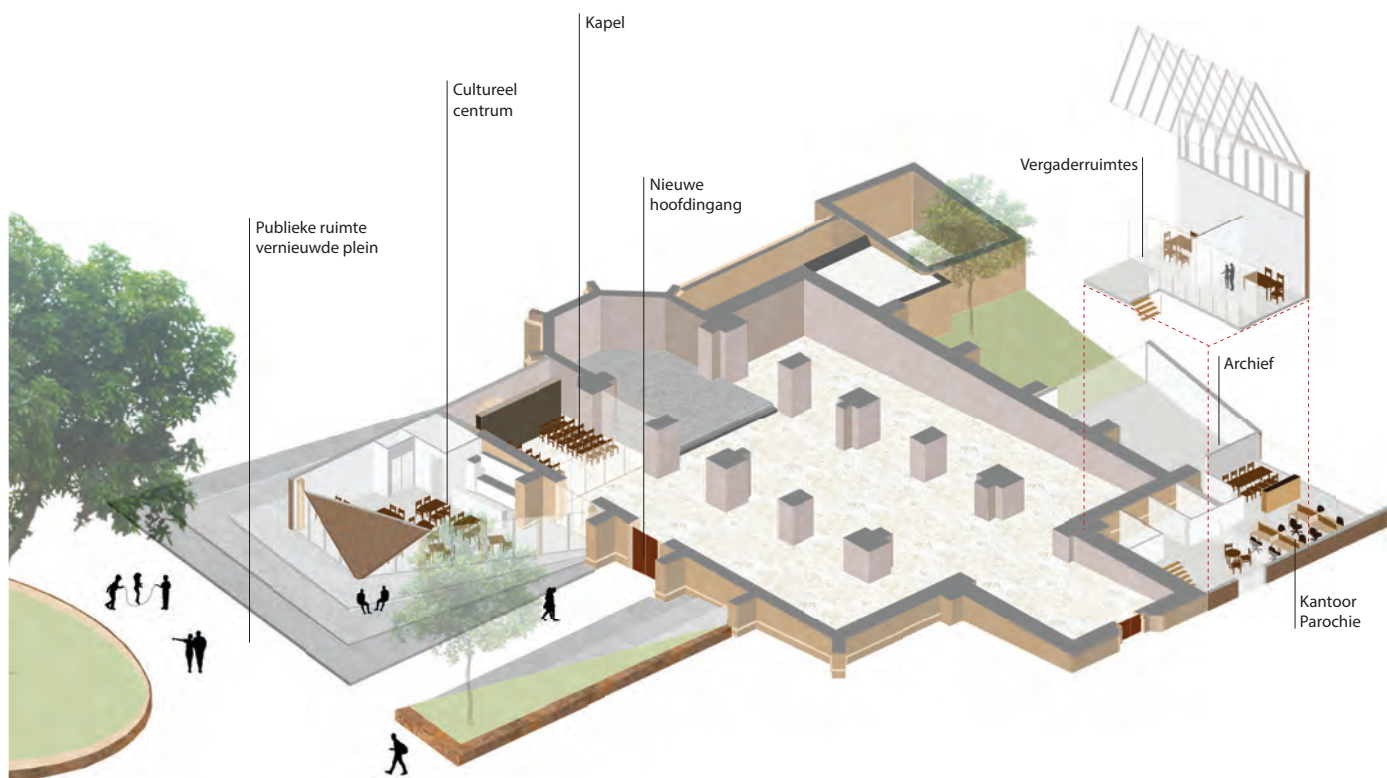

Exterieur plein



Interieur cultureel centrum



Interieur kantoor

# NIEUWSTADSKERK ZUTPHEN

René Sondermeijer  
Nederland

## Een hernieuwd stukje Nieuwstad

Na de reorganisatie van de lokale parochieën in Zutphen, is de Nieuwstadskerk aangewezen als hoofdkerk van de collectieve parochie de Twaalf Apostelen. Als ondersteuning van dit collectief, is er behoefte ontstaan voor een nieuw Eucharistisch centrum als uitbreiding van de Nieuwstadskerk, dat voorziet in werkruimte voor het parochiebestuur en gemeenschappelijke ruimtes voor de kerkgemeenschap.

Het Hubertusplein, waaraan de Nieuwstadskerk gelegen is, bevindt zich bij de ingang van het Vogelpark. Door deze ligging kan het plein uitstekend fungeren als ondersteunende rol voor het park. Hiertoe is er een losstaand kleinschalig horecapaviljoen aan het programma toegevoegd, dat zowel de kerk als het park kan ondersteunen. Door de ruimtelijke schikking van de functies (kerk, parochiecentrum en horecapaviljoen) wordt er een intieme centrale binnenplaats gecreëerd met de Nieuwstadskerk als decor, die gebruikt kan worden door zowel de kerk als het horecapaviljoen. Met deze ingreep is er een integraal plan ontwikkeld waarin verschillende gemeenschappen binnen Zutphen samen kunnen komen en gebruik kunnen maken van een hernieuwd stukje Nieuwstad.

De functies voor het Eucharistisch centrum zijn ondergebracht in één gebouw. De ruimtes voor de parochiegemeenschap zijn gesitueerd op de begane grond. Centraal hierin ligt een grote multifunctionele ruimte die door de parochie gebruikt kan worden voor verschillende activiteiten. Deze ruimte is door middel van transparante uitbouw fysiek en visueel met de binnenplaats verbonden. Het kerkbestuur heeft haar werkplekken op de eerste en tweede verdiepingen, waarbij er gezocht is naar een duidelijke visuele relatie met de begane grond door de implementatie van een vide over de gehele lengte van het gebouw.

De aanbouw is door het gebruik van een grove steen monolithisch vormgegeven waarbij de daklijn op een eigentijdse manier refereert aan de omliggende bebouwing. In materialisering wordt zowel in het interieur als in het exterieur op een subtiele wijze gecontrasteerd met de bestaande bouw. Waar in het exterieur de monolithische vormgeving zorgt voor dit contrast, wordt dit binnenin bereikt door een strakke witte uitstraling met daarin de oorspronkelijke gevel van de Nieuwstadskerk als in het oog springend element.

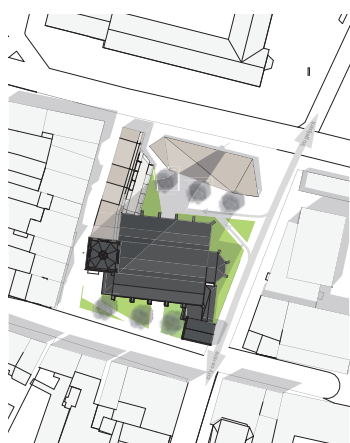

stedelijke situering

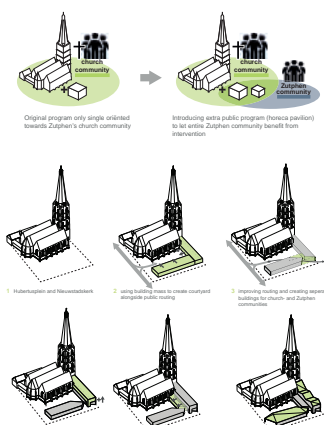

ontwerpconcept



langsdoorsnede t.p.v. aansluiting met kerk



dwarsdoorsnede binnenplaats en gemeenschapsruimte



Eucharistisch Centrum, gezien vanuit Isendoornstraat



# NIEUWSTADSKERK ZUTPHEN

René Sondermeijer  
Nederland

Een hernieuwd stukje Nieuwstad

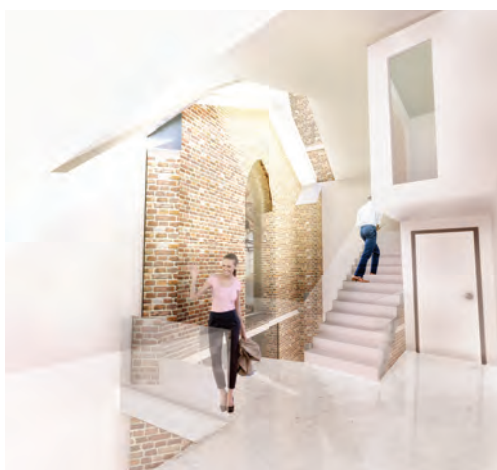

Interieur, aansluiting met bestaande bouw



Interieur, multifunctionele gemeenschapsruimte

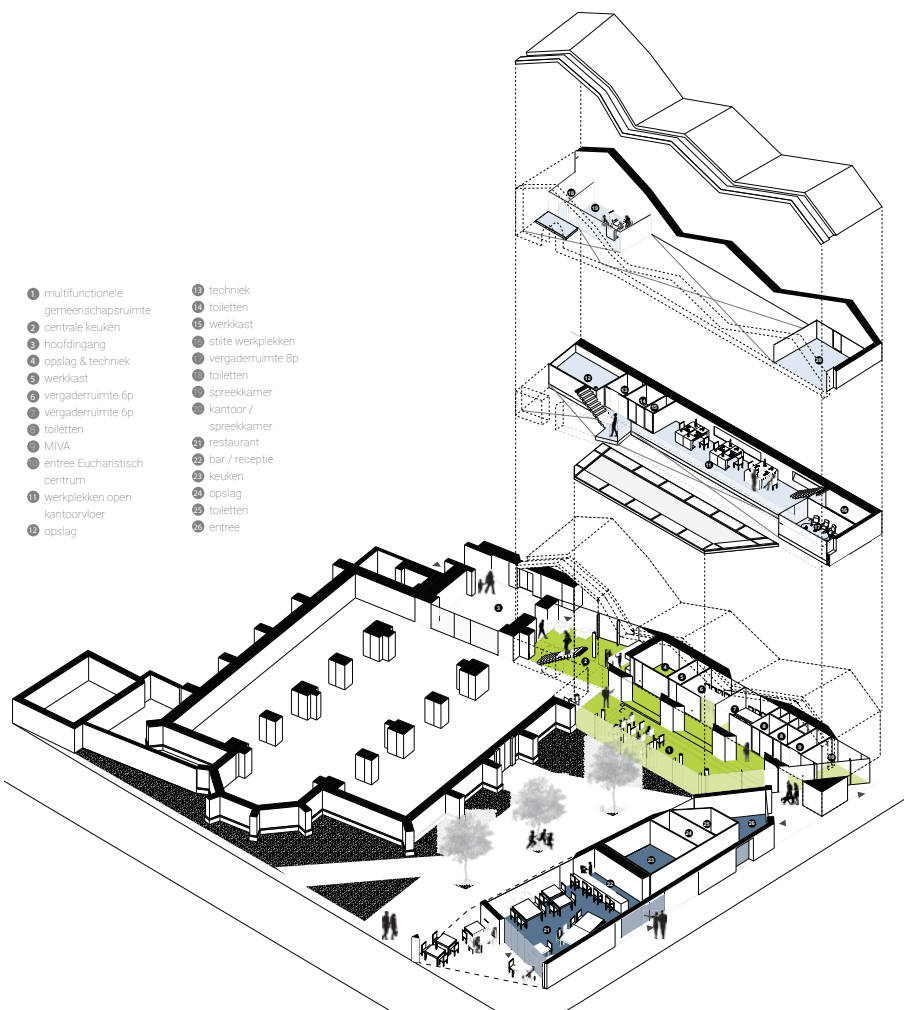

- 1 multifunctionele gemeenschapsruimte
- 2 centrale keuken
- 3 hoofdingang
- 4 opslag & techniek
- 5 werkkast
- 6 vergaderruimte 6p
- 7 vergaderruimte 6p
- 8 toiletten
- 9 MIVA
- 10 entree Eucharistisch centrum
- 11 werkplekken open kantoorvloer
- 12 opslag
- 13 techniek
- 14 toiletten
- 15 werkkast
- 16 stiltewerkplekken
- 17 vergaderruimte 8p
- 18 toiletten
- 19 spreekkamer
- 20 kantoor / spreekkamer
- 21 restaurant
- 22 bar / receptie
- 23 keuken
- 24 opslag
- 25 toiletten
- 26 entree

Ruimtelijke opzet



Centrale binnenplaats

# NIEUWESTADSKERK, ZUTPHEN

Lars van Straalen  
The Netherlands

An addition to religious heritage, the community building

## Starting points

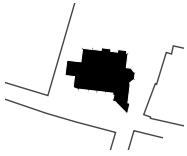

### Urban context

The urban context consists of educational and living functions. The separation of these to be clearly seen in the urban fabric. The contrast between big versus small and old versus new architecture splits the character. Right at the crossing between this tension field the church is situated. The addition to the church tries to give the urban space a better ratio between built and unbuilt by following the contextual alignment.



### Building

The articulation of building volumes is characteristic, because the height width ratio focuses on the height of the tower. The way the building touches the ground is emphasized by the way the buttresses support the church walls. The horizontal direction can be found in the natural stone line which connects the window frames and highlights the point where the building batters, in other words 'gets fatter'.



### Community

Church as the mid point of the living quarter. Where the church serves as a platform to bring people together. The addition is only there to support this function by providing the serving necessities to support this platform.



### Church

Additionally to the given program, private serving functions to facilitate the parish, there was a need for informal and formal event spaces where any kind of activities could be organized. The new building wants to serve the church building in its religious function but also providing the opening up to the surroundings.

## Concept



### DIRECTIONS

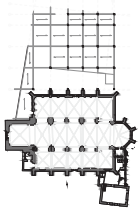

### STRUCTURE

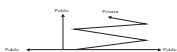

### PROGRAM

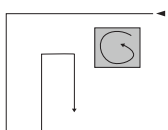

### CIRCULATION



Impression



# NIEUWESTADSKERK, ZUTPHEN

Lars van Straalen  
The Netherlands

An addition to religious heritage, the community building

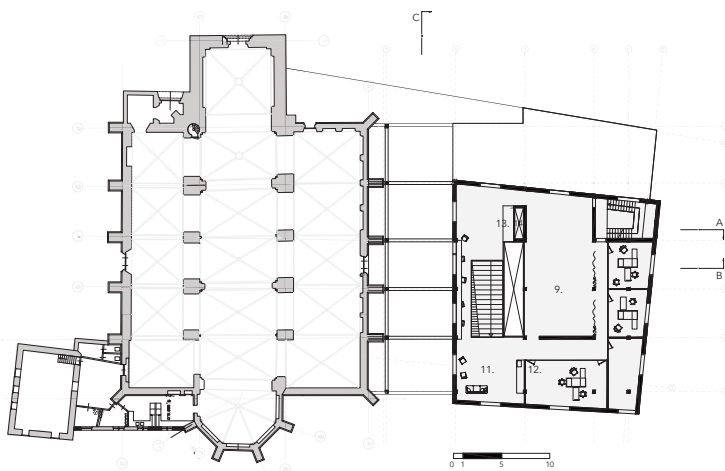
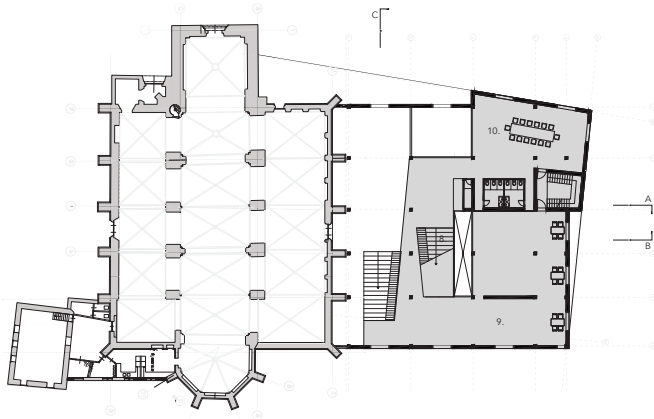
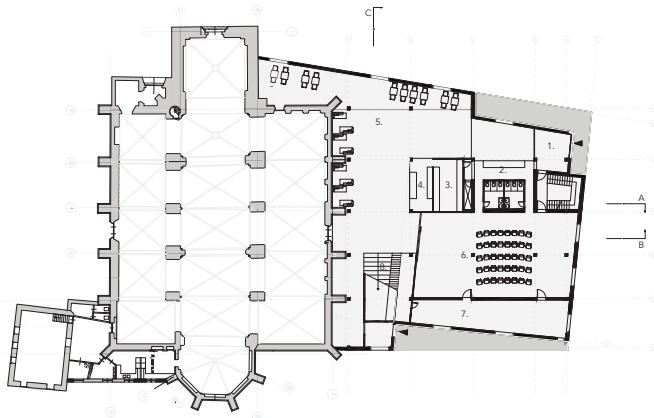

- |                                |                          |
|--------------------------------|--------------------------|
| 1. Reception counter, wardrobe | 9. Studio space          |
| 2. Toilets                     | 10. Meeting room         |
| 3. Kitchen                     | 11. Pantry               |
| 4. Coffee/food counter         | 12. Church office spaces |
| 5. Informal meeting space      | 13. Storage              |
| 6. Event space                 | 14. Technical space      |
| 7. Studio                      |                          |
| 8. Grand stair                 |                          |

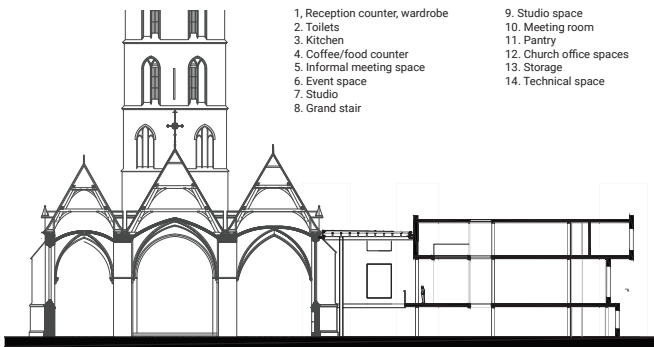

PLANS AND SECTION B



VIEW TO MEETING SPACE  
Repetition of church nave space



VIEW FROM ENTRANCE TO CHURCH  
Sequence of space entering the church facade



ELEVATION PART OF FACADE

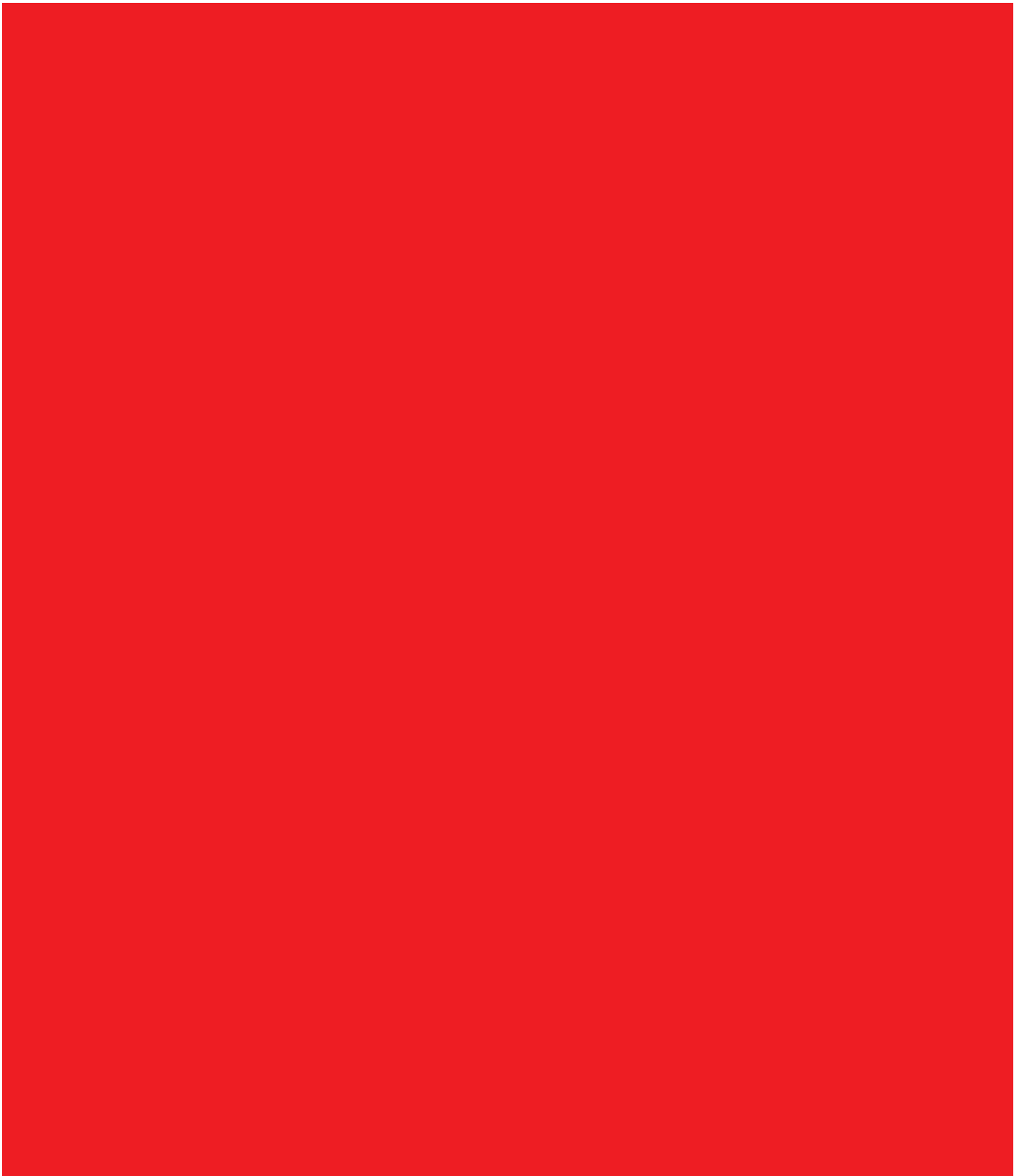

Technische Universiteit Delft - Faculteit Bouwkunde  
Afdeling Architectural Engineering + Technology  
Sectie Heritage & Architecture

Julianalaan 134 | 2628 BL Delft

